

# Phase II

Shaun Alsum

New Stuff

# Vessel in place!



# Breakout parts

- All parts needed for breakout ordered, located, or in-hand
- Need PMT HV FT from PSL still

	A	B	C
1	Part	#Needed	#In Possession
2	6"->4-5/8" ZLR	2	0
3	3' long 4-5/8" CF conduit	1	1
4	4-5/8" CF elbow	1	2
5	18" long 4-5/8" CF bellows	1	1
6	12" long 4-5/8" CF tube	1	1
7	4-5/8" CF T	4	4
8	4-5/8"->8" ZLR	2	2
9	8" CF 5-way	1	0
10	8" CF 4xD25 FT	1	0
11	PMT HV Box	1	1
12	8" PMT Sig FT flange	1	0
13	PMT Sig Filter Box	1	1
14	4-5/8" CF 2xD25 FT	1	1
15	4-5/8" Marty's HV FT flange	2	0
16	4-5/8" CF valve	1	1
17	4-1/2" turbo pump	1	0
18	4-5/8" -> 2-3/4" CF ZLR	1	2
19	2-3/4" Hornet	1	0
20	2-3/4" Worker Bee	1	0
21	2-3/4" -> VCR FT	2	2
22	3-3/8" -> 2-3/4" ZLR	1	1
23	2-3/4" 5-way cf	1	1
24	2-3/4" blank	1	1

Old stuff



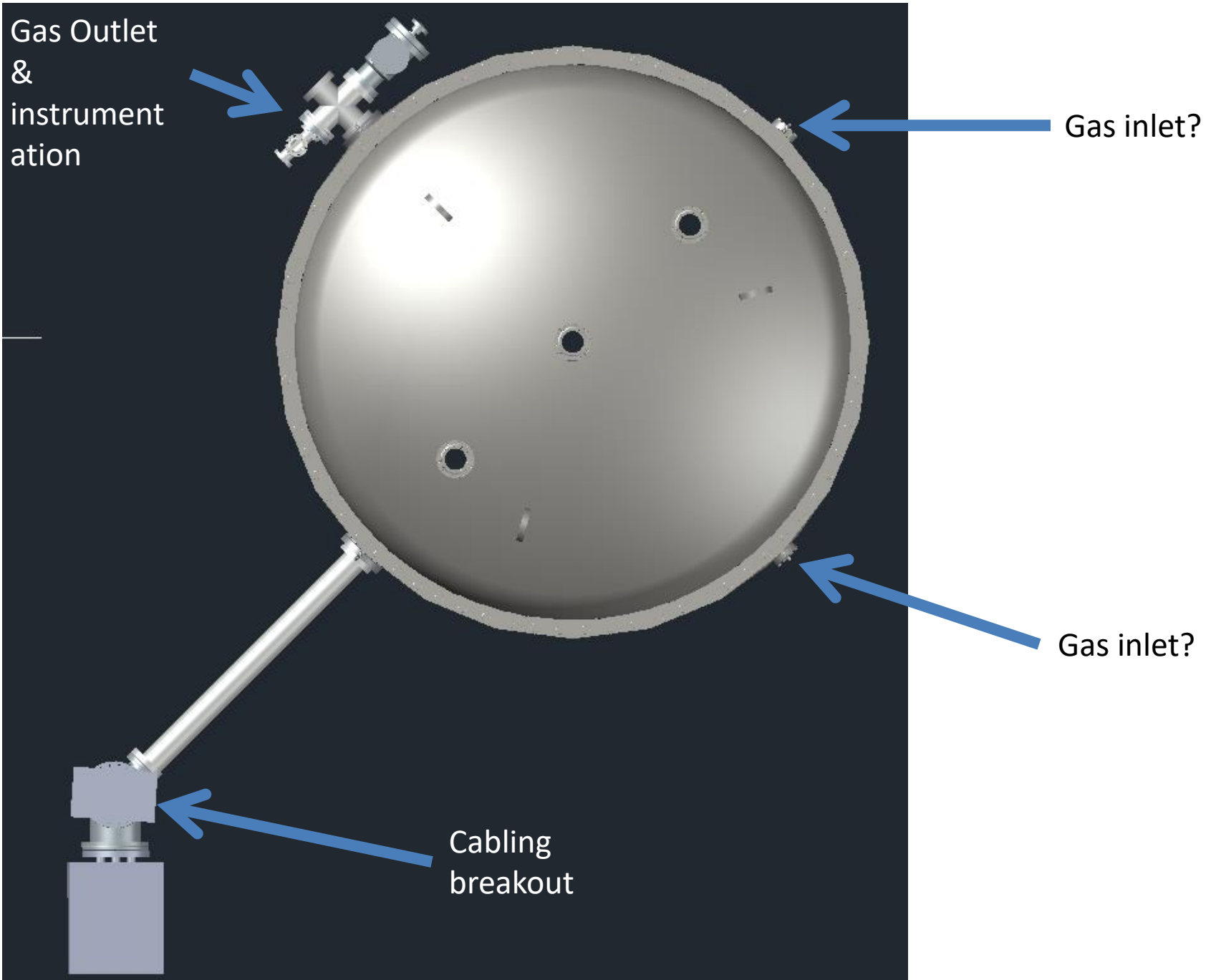

Gas Outlet  
&  
instrumentation

Gas inlet?

Gas inlet?

Cabling  
breakout

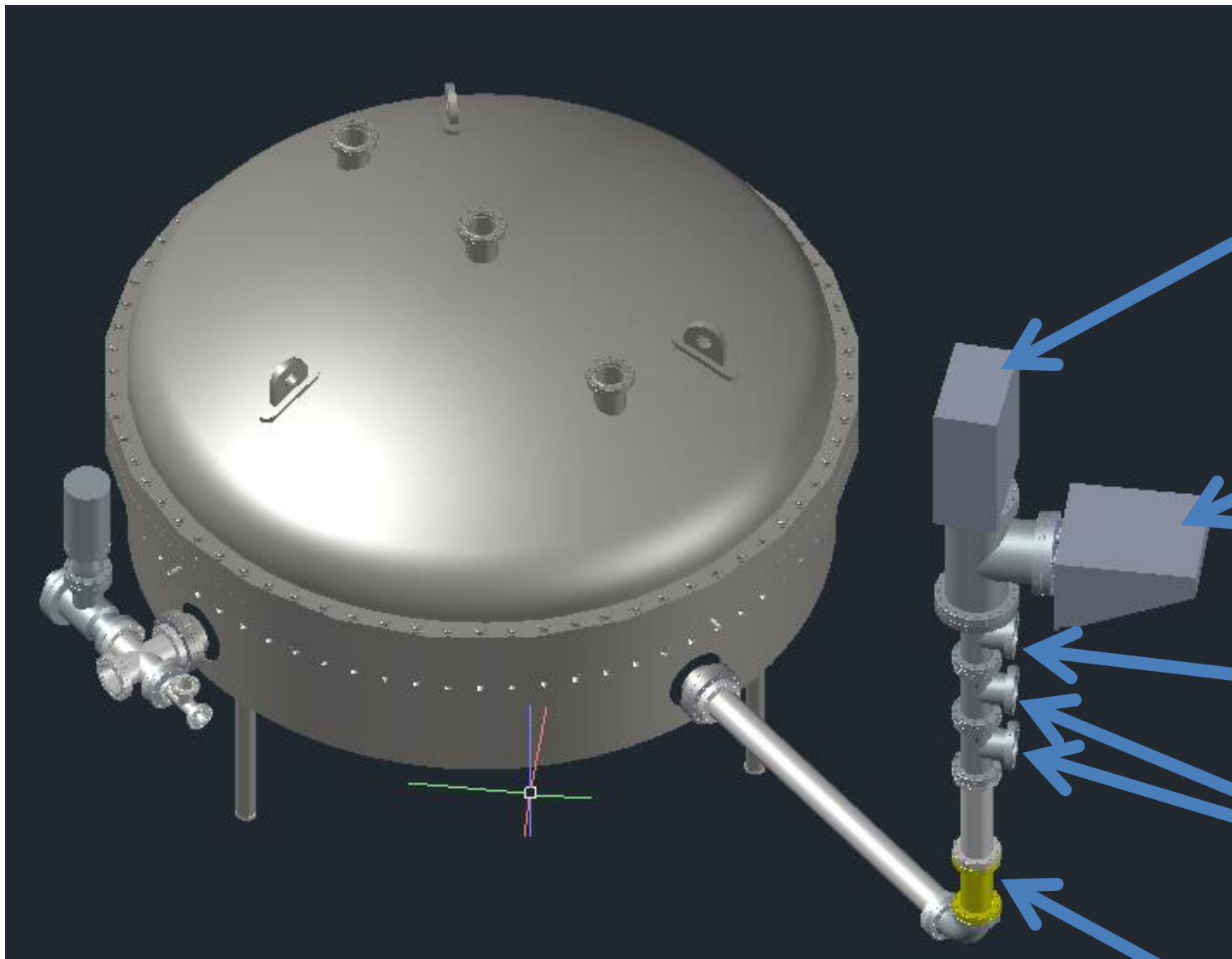

PMT Sig  
filter box

PMT HV FT  
box

LED,  
Camera, LA

Grid/hoop/  
refl plate  
HV

Bellows



Turbo

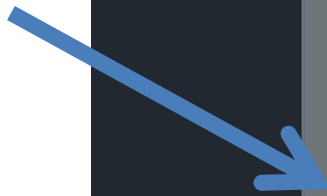

To VCR outlet on which >1bar pressure gauges



Hornet



Worker bee

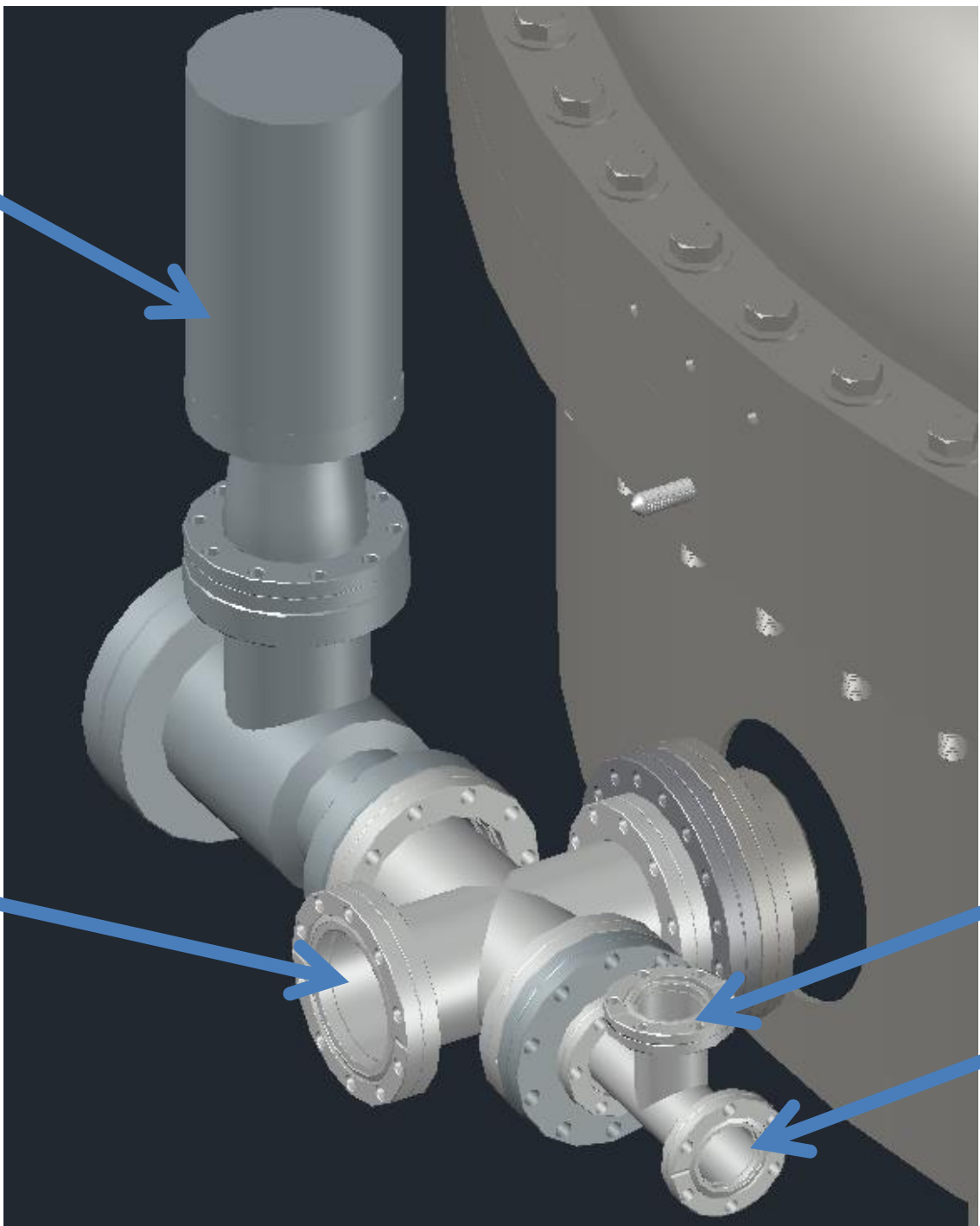

# PMT cable length estimates

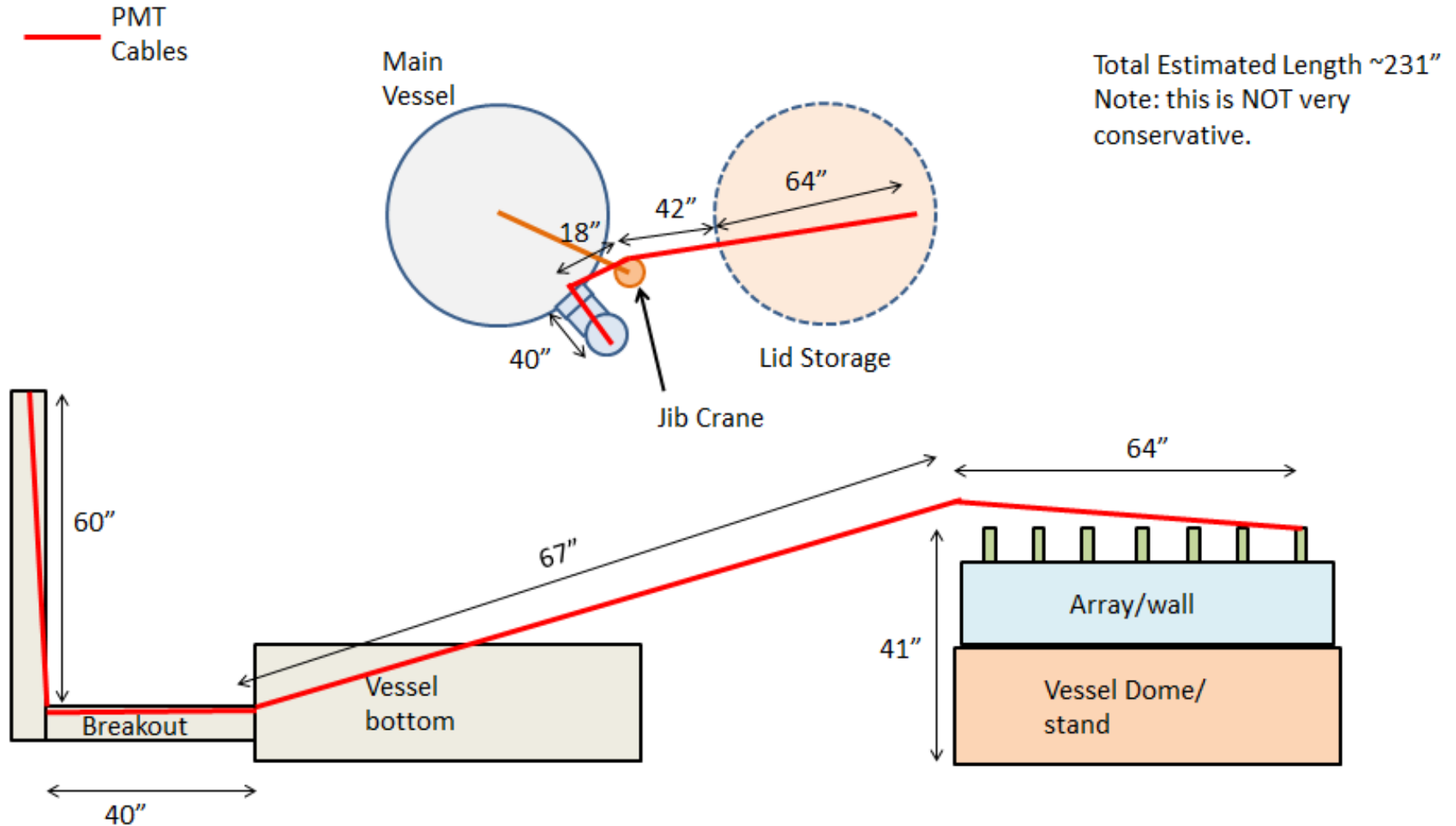

# System Test Phase II - LZ

- Large Vessel designed to test the LZ field generating grids in Xe gas.

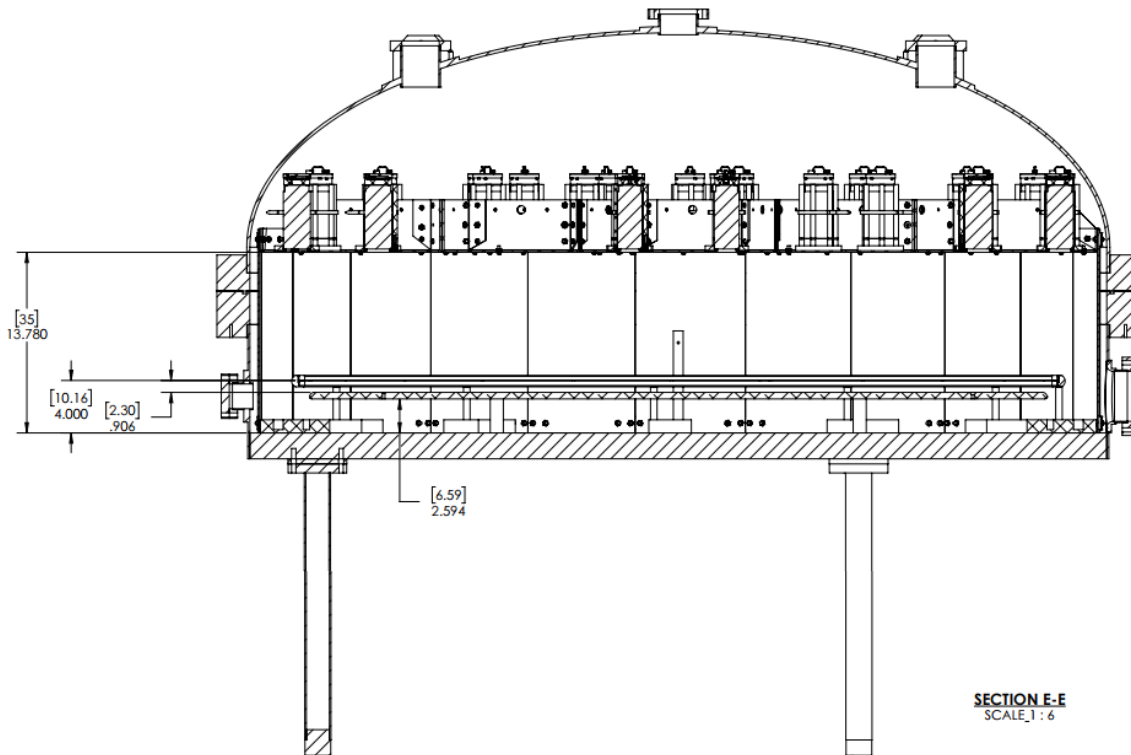

CONFIGURATION:

# Gas Circulation

Assist in concept, design, and construction of Phase II/Gas Test gas system

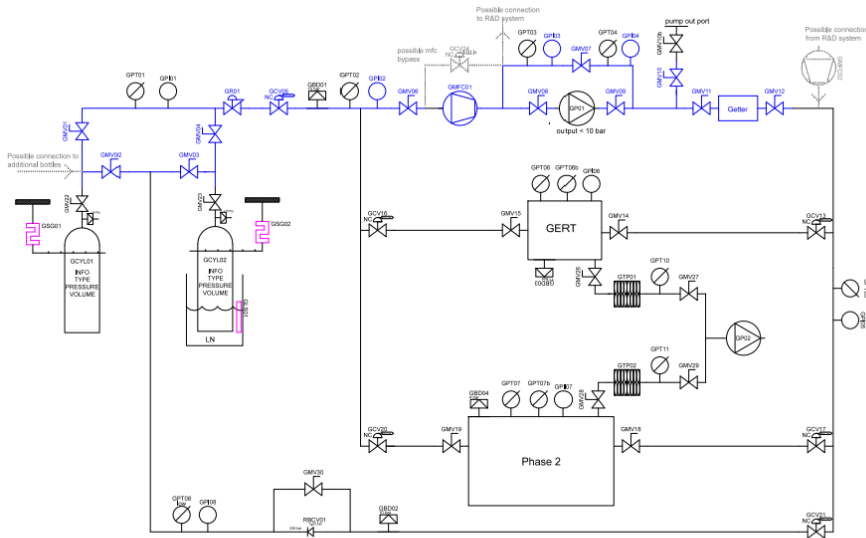

Title: LZ R&D Phase 2 and GERT P&ID  
Version 1.0: April 25, 2017  
SLAC National Accelerator Laboratory  
Reviewed by: Christine Brown (gbrwn@slac.stanford.edu)

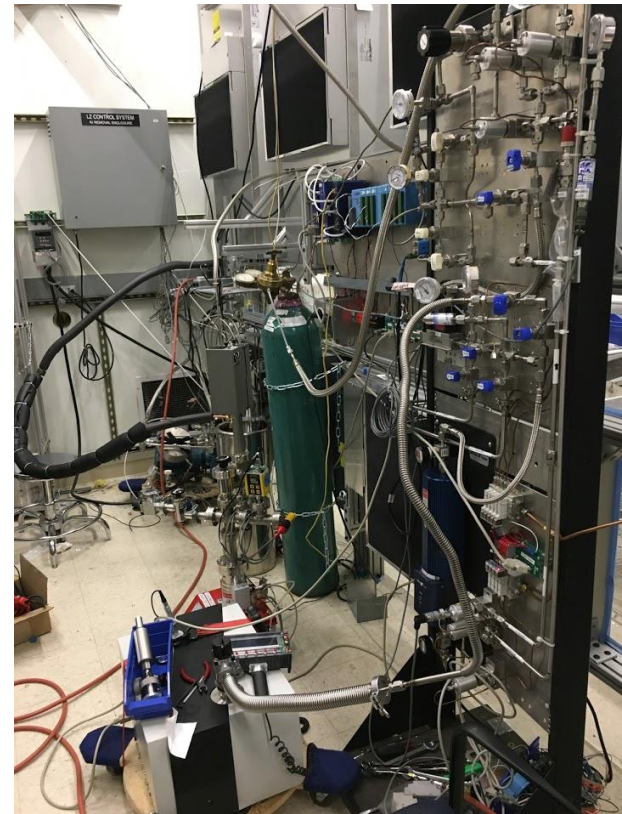

# PMT connections

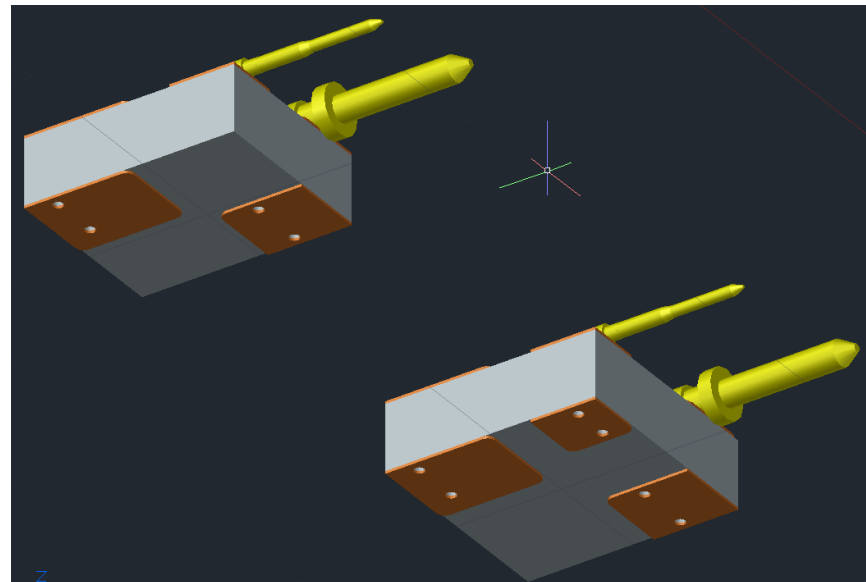
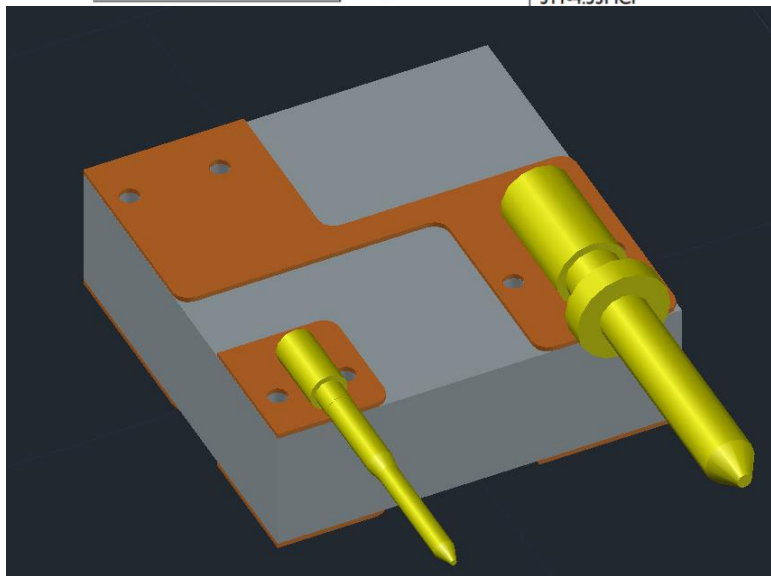
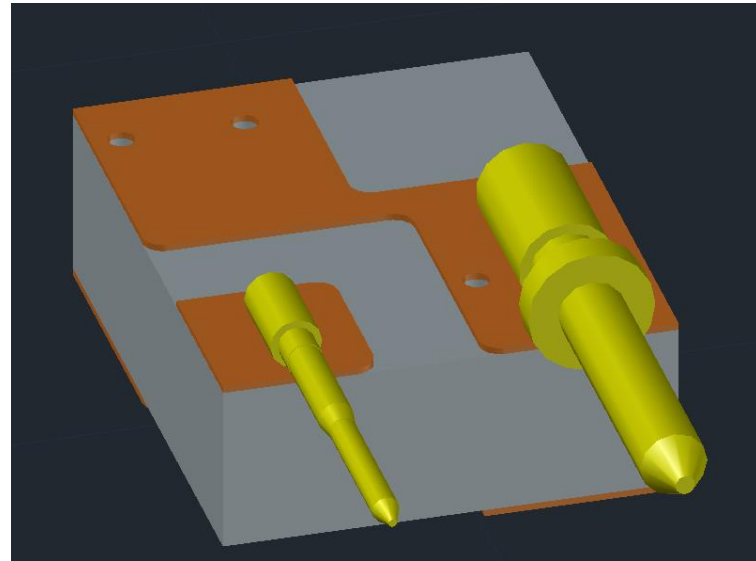
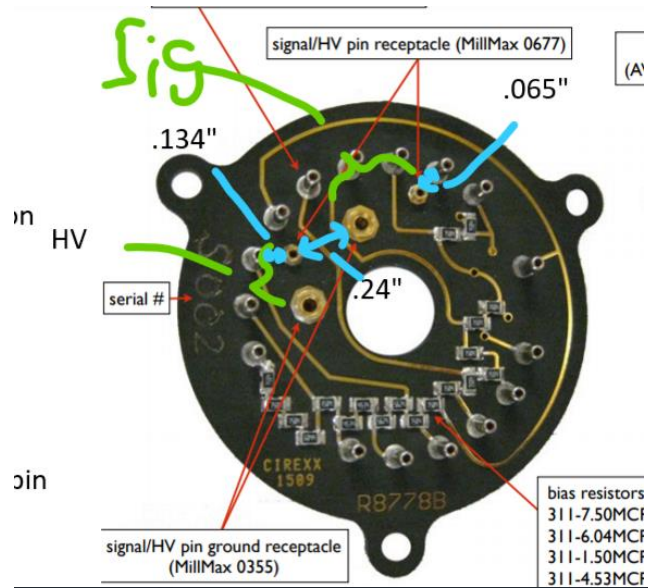

# PMT array test assembly

- 43 bent sheet metal pieces
- Ensure they fit correctly and withstand manipulation and stress
- Thorough cleaning

