

Phase II

Shaun Alsum

New Stuff

Sending stuff to Madison

- Finalized connector design for steffen
- Got final PMT base connectors
- Assembled materials
- Sent to Madison

Determining grid HV cable routing

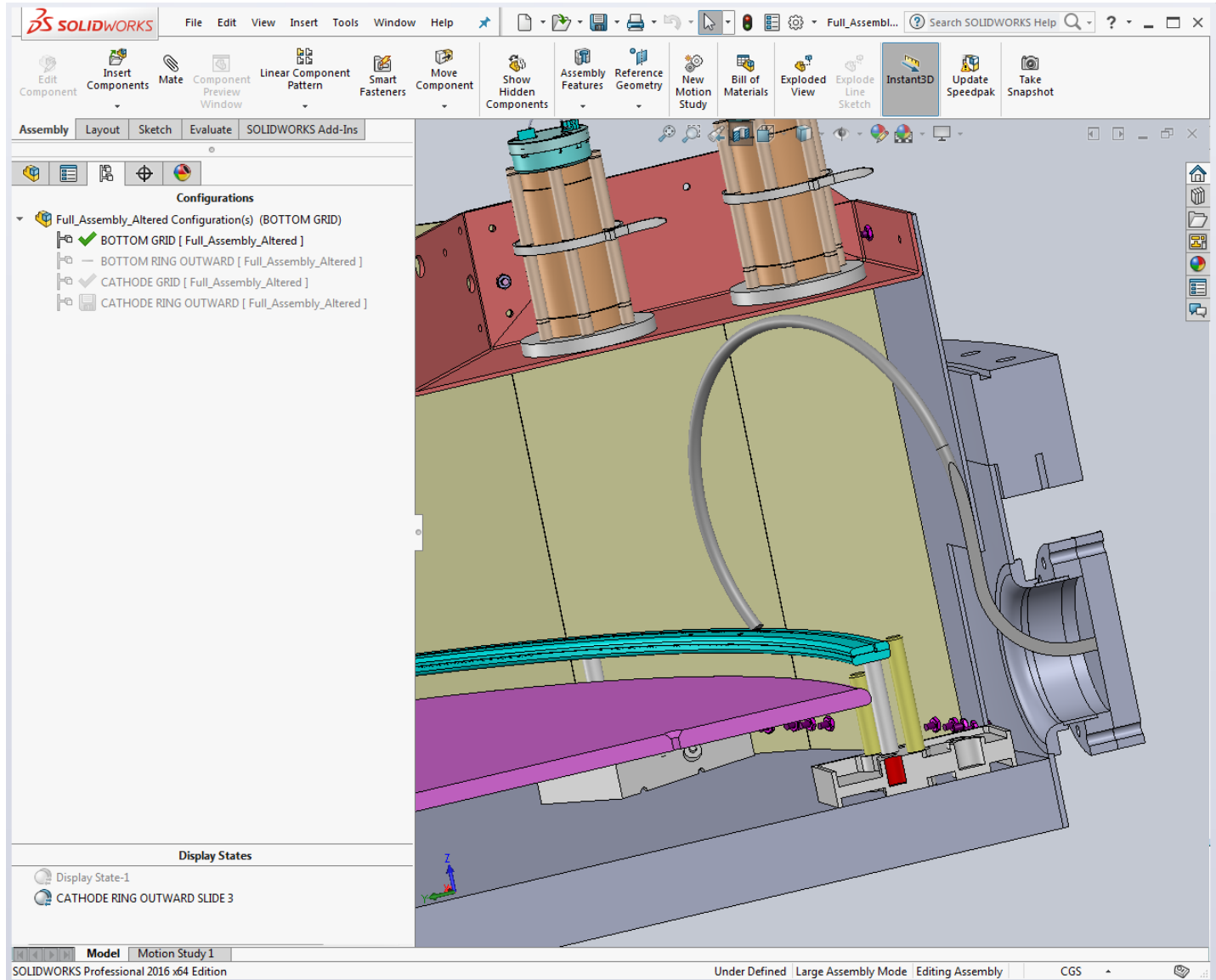

Old stuff

Minor things progress

- Thinking about attaching HV to grids/plates/field hoops
- Steffen volunteered to make the PMT connectors
- LED/Camera decisions
- Located some wire, estimated how much needed, etc.

Vessel in place!



Breakout parts

- All parts needed for breakout ordered, located, or in-hand
- Need PMT HV FT from PSL still

	A	B	C
1	Part	#Needed	#In Possession
2	6"->4-5/8" ZLR	2	0
3	3' long 4-5/8" CF conduit	1	1
4	4-5/8" CF elbow	1	2
5	18" long 4-5/8" CF bellows	1	1
6	12" long 4-5/8" CF tube	1	1
7	4-5/8" CF T	4	4
8	4-5/8"->8" ZLR	2	2
9	8" CF 5-way	1	0
10	8" CF 4xD25 FT	1	0
11	PMT HV Box	1	1
12	8" PMT Sig FT flange	1	0
13	PMT Sig Filter Box	1	1
14	4-5/8" CF 2xD25 FT	1	1
15	4-5/8" Marty's HV FT flange	2	0
16	4-5/8" CF valve	1	1
17	4-1/2" turbo pump	1	0
18	4-5/8" -> 2-3/4" CF ZLR	1	2
19	2-3/4" Hornet	1	0
20	2-3/4" Worker Bee	1	0
21	2-3/4" -> VCR FT	2	2
22	3-3/8" -> 2-3/4" ZLR	1	1
23	2-3/4" 5-way cf	1	1
24	2-3/4" blank	1	1

Breakout

Hut layout to orient you. Sorry words are sideways

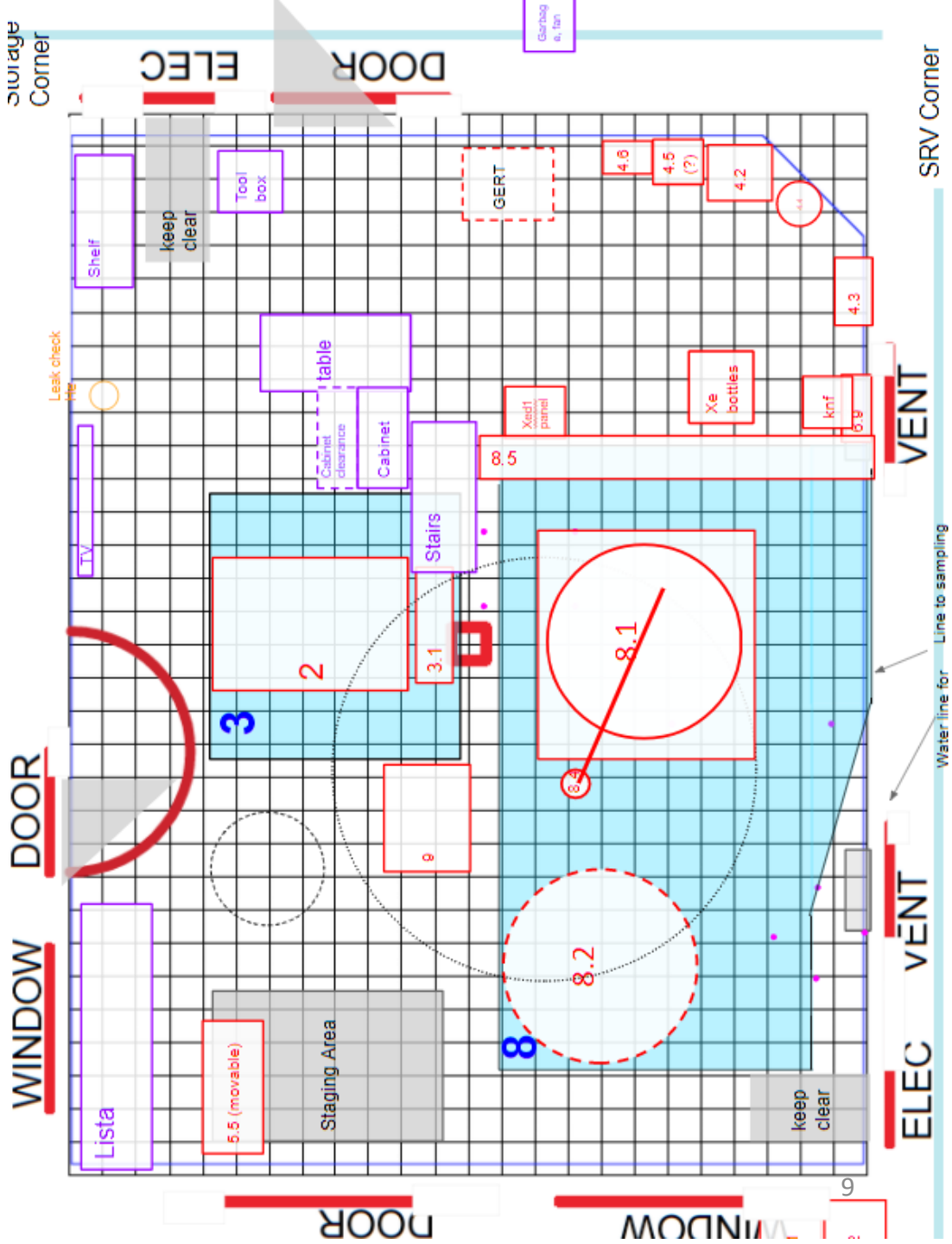

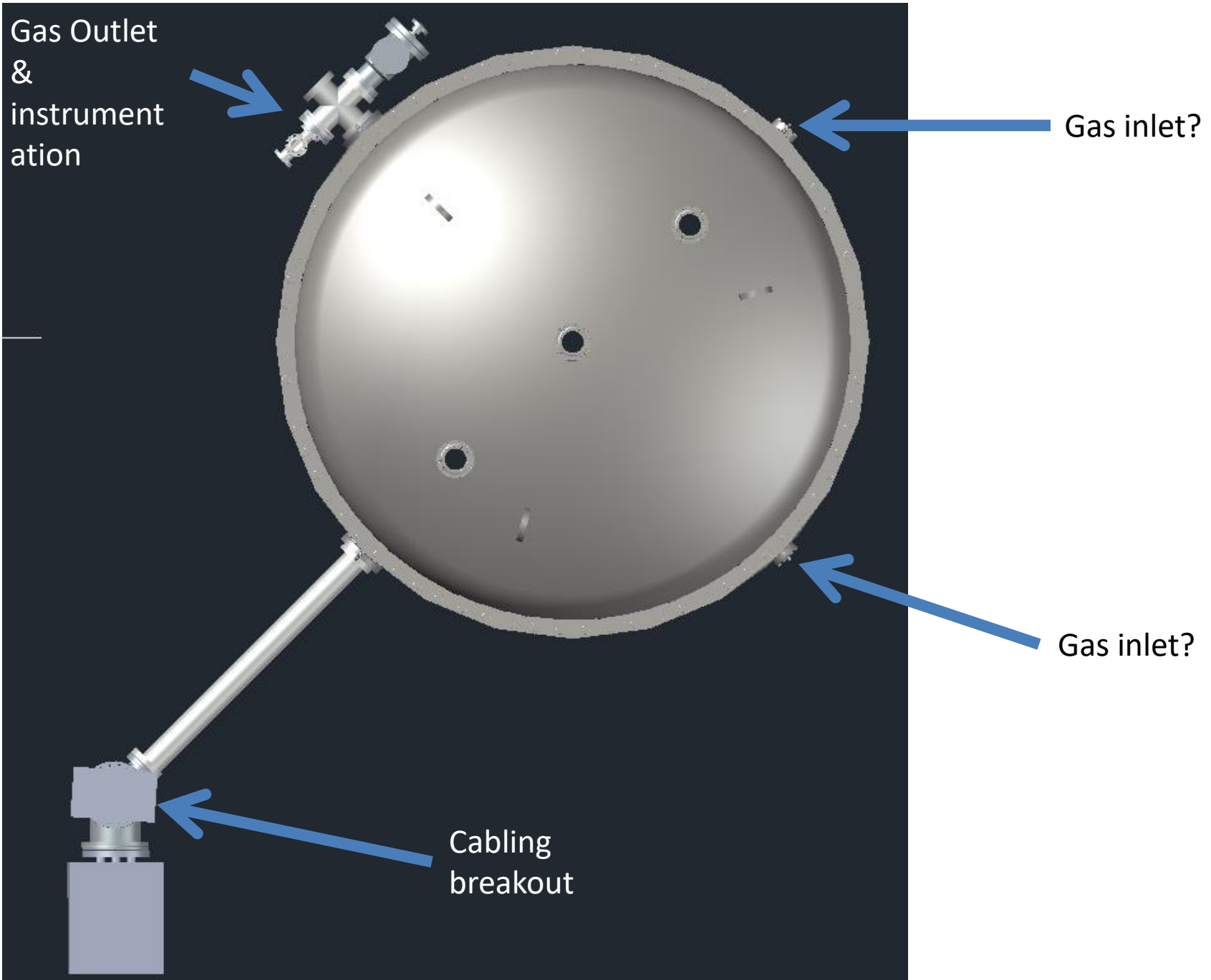

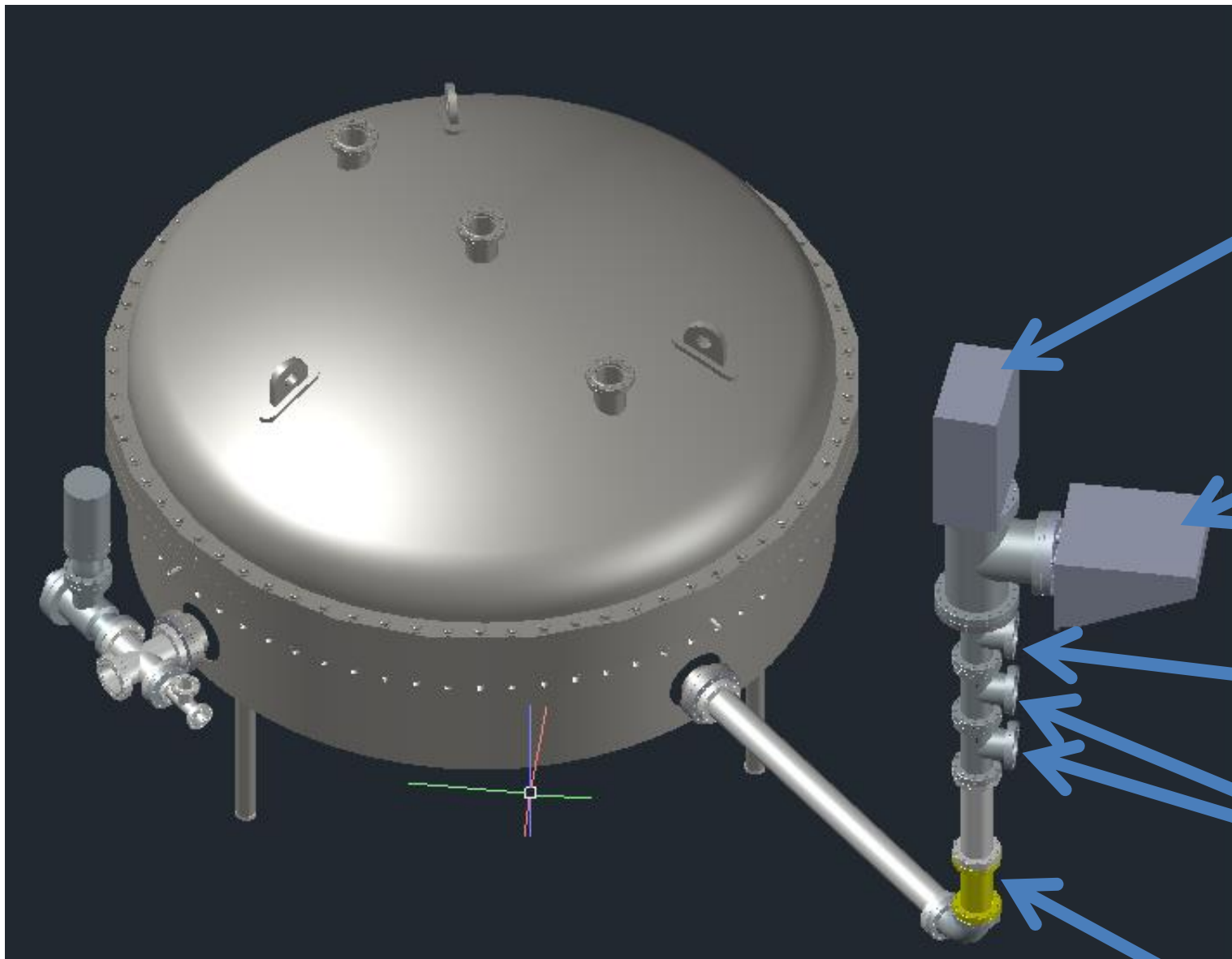

PMT Sig
filter box

PMT HV FT
box

LED,
Camera, LA

Grid/hoop/
refl plate
HV

Bellows

Turbo

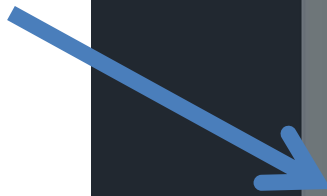

To VCR outlet on which >1bar pressure gauges



Hornet



Worker bee

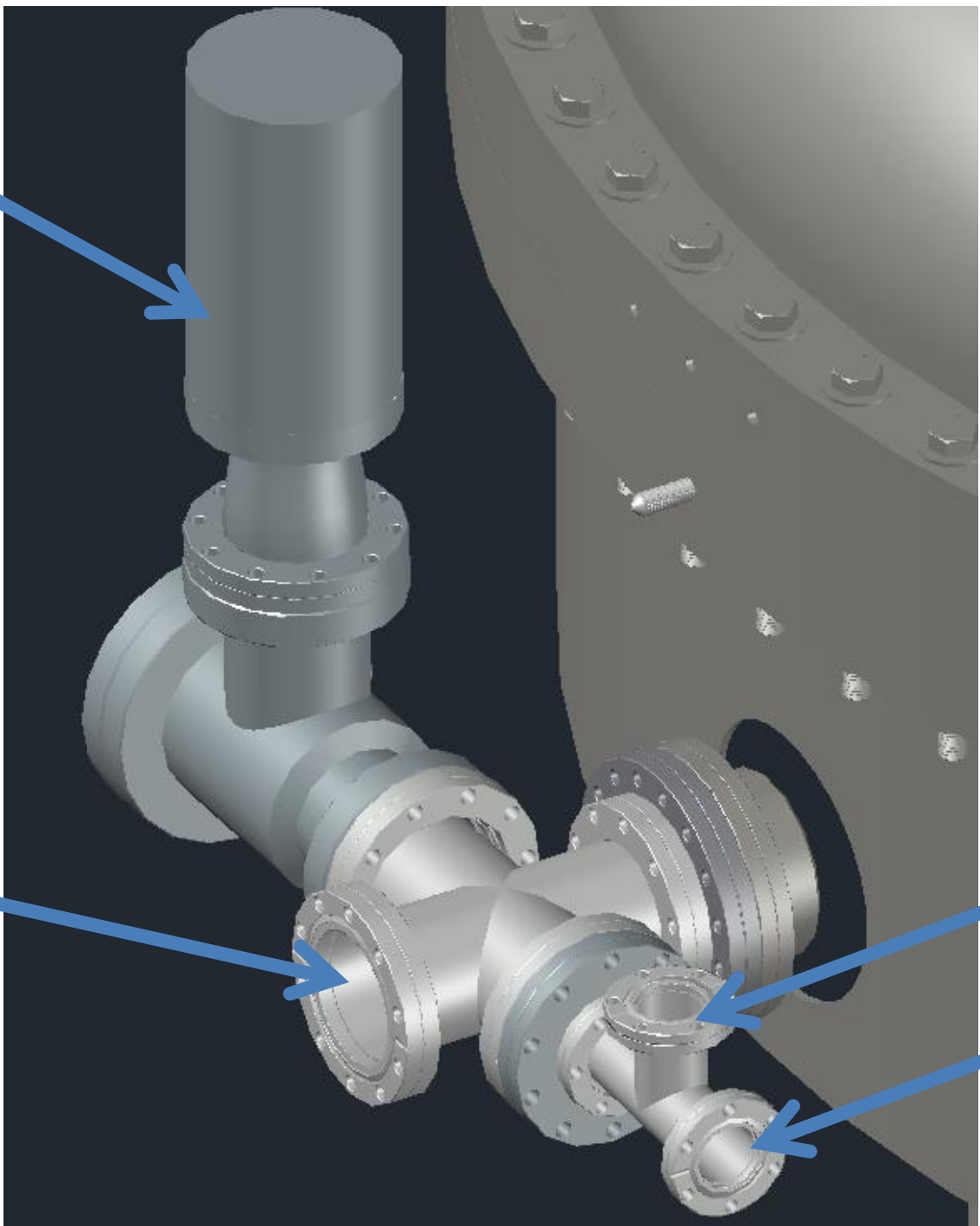

PMT cable length estimates

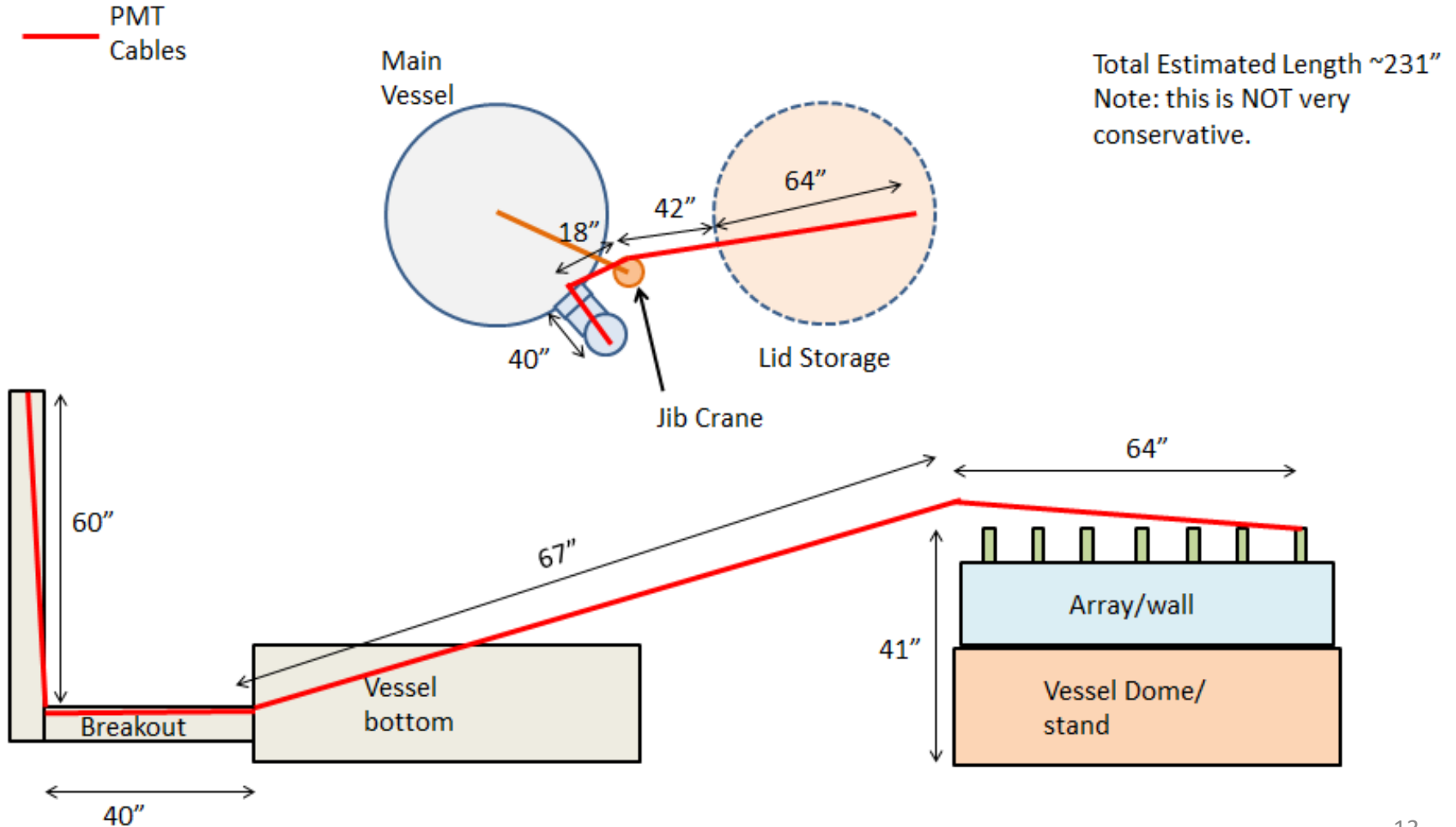

System Test Phase II - LZ

- Large Vessel designed to test the LZ field generating grids in Xe gas.

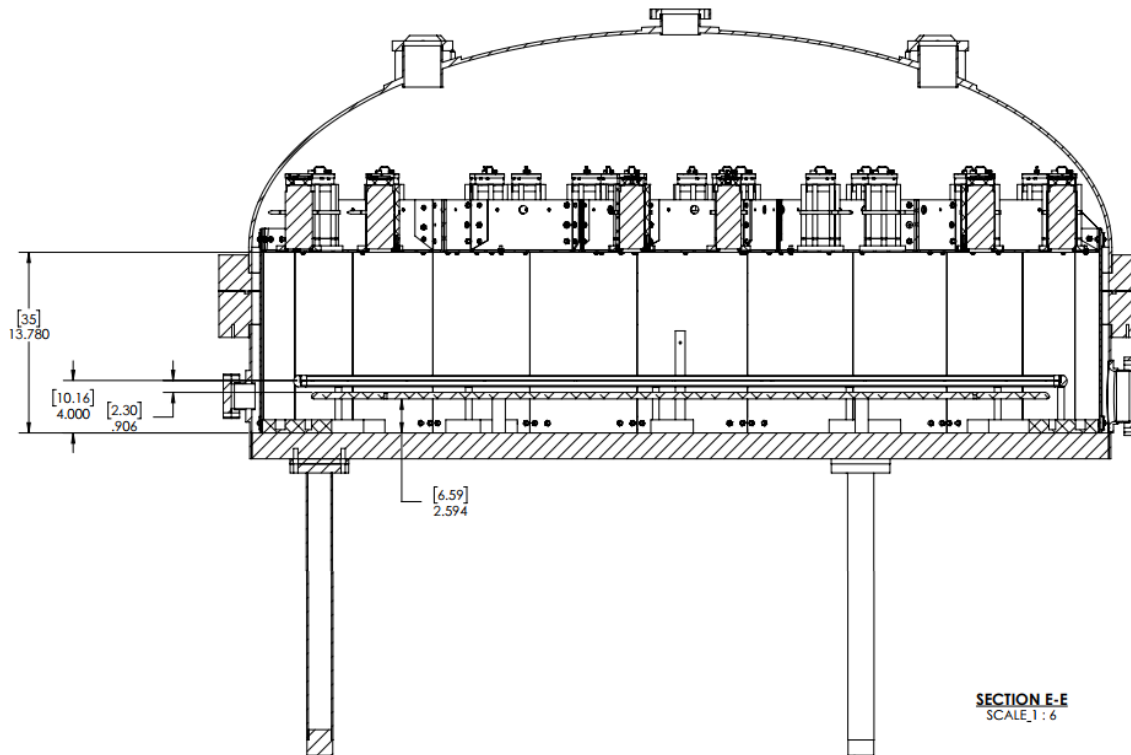

CONFIGURATION:

Gas Circulation

Assist in concept, design, and construction of Phase II/Gas Test gas system

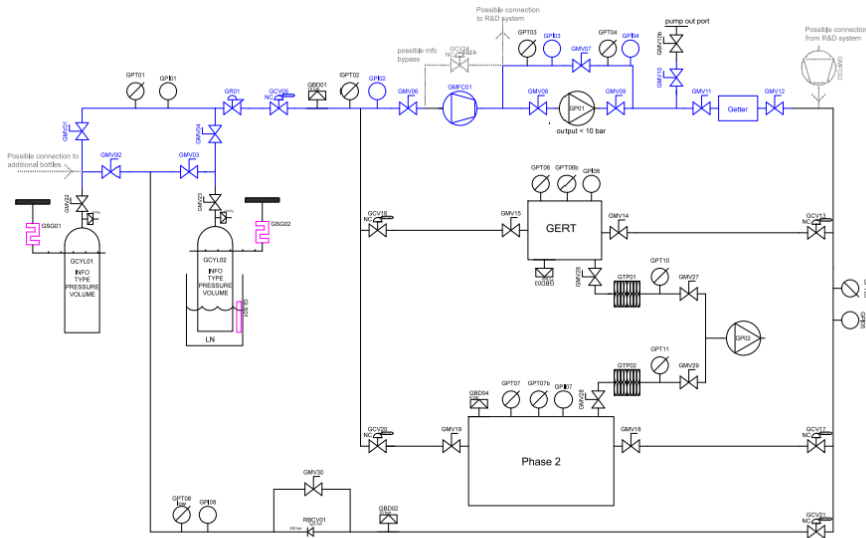

Title: LZ R&D Phase 2 and GERT P&ID
Version 1.0: April 25, 2017
SLAC National Accelerator Laboratory
Reviewed by: Christine Brown (christine@slac.stanford.edu)

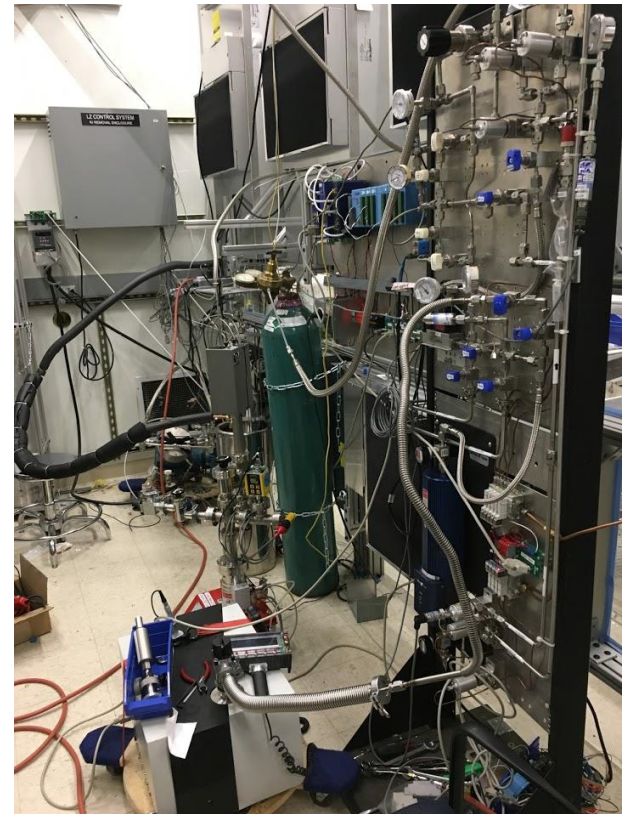

PMT connections

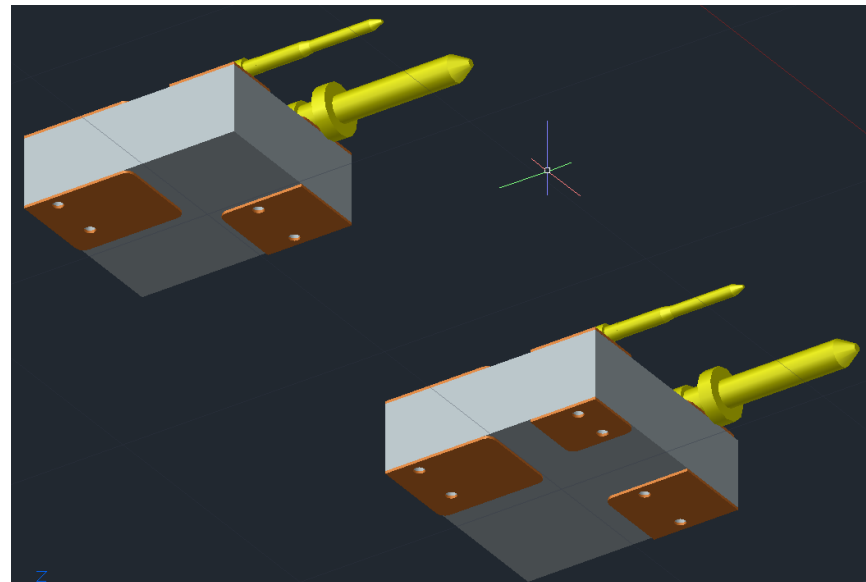
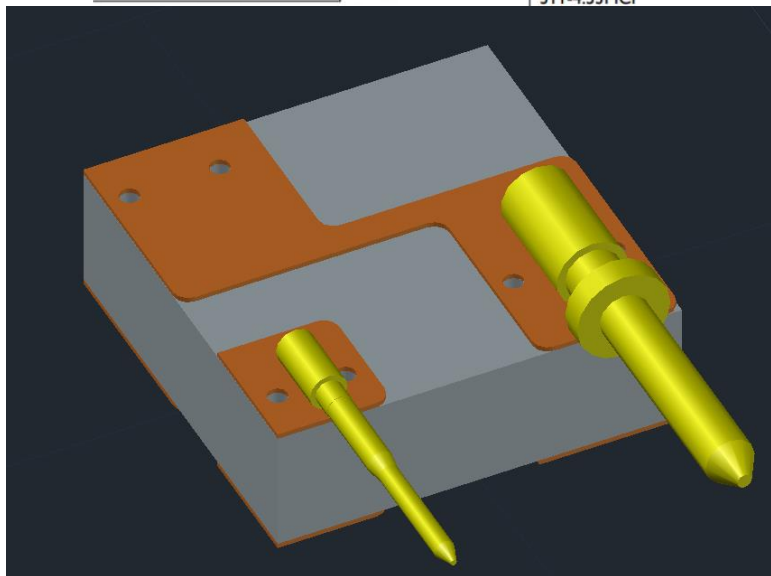
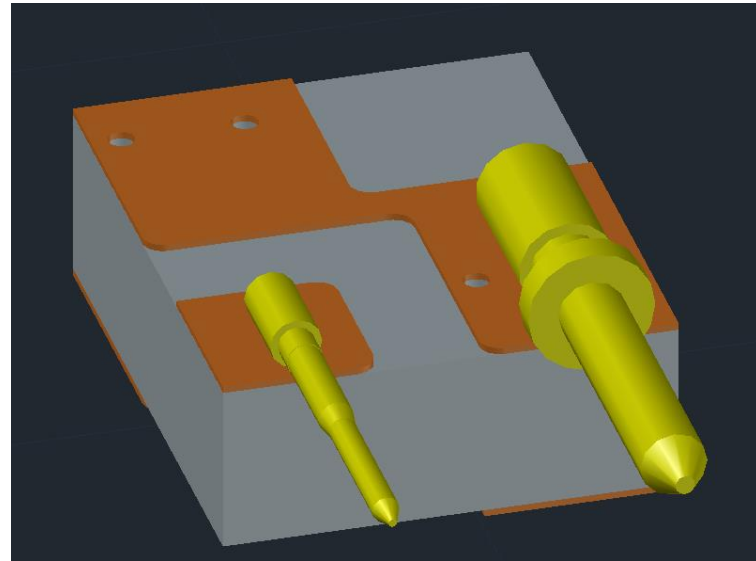
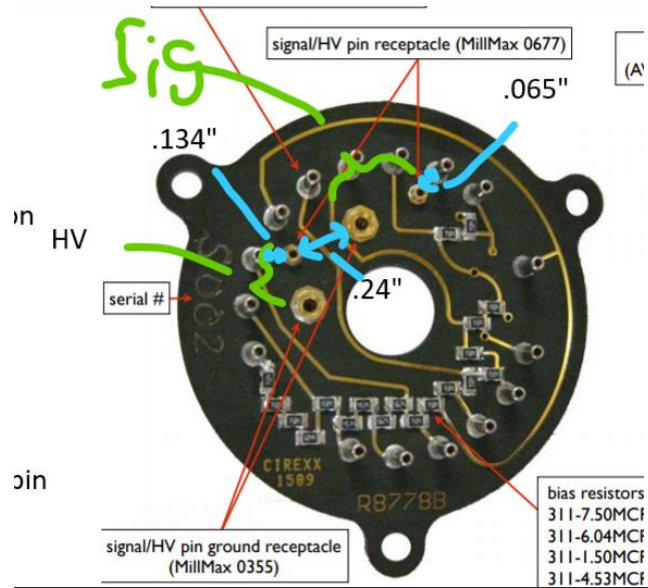

PMT array test assembly

- 43 bent sheet metal pieces
- Ensure they fit correctly and withstand manipulation and stress
- Thorough cleaning



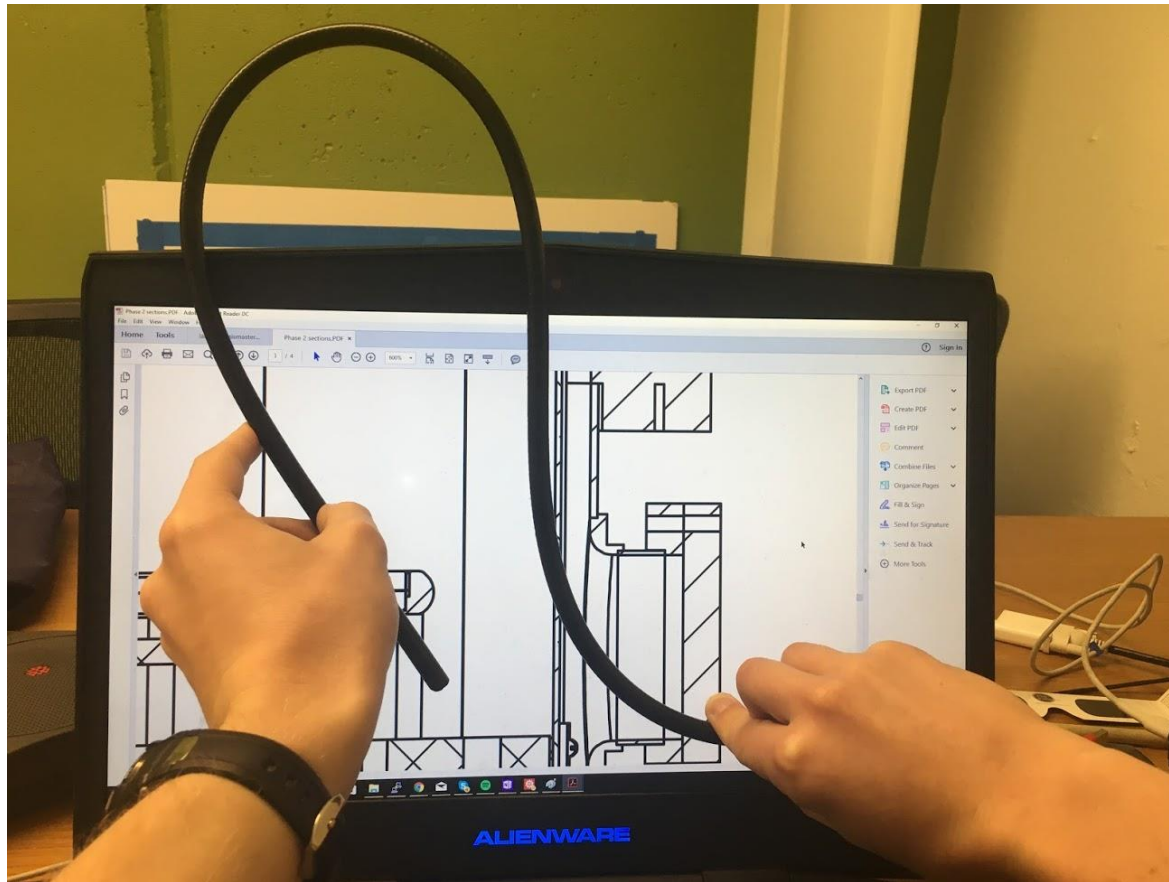

Designing HV cable routes and terminations to grids, rings, hoops, etc.

Breakout

- Test-build completed
- Measured, constructable
 - Need to cut some threaded rods shorter
- “Stand” built



Jib crane and Lid Placement

- Jib crane installed
 - Different location than originally planned
 - Middle of the room, alters where we put the lid
- Lid location decided upon and marked
 - Clears the Jib crane by ~1 inch and extends ~2-3 inches outside cleanroom on the side.
 - Curtain moves so should be fine

PMT base connector progress

- Prototype connectors made
 - Pins fit well
 - Quite robust
 - Plugged and unplugged ~15 times
 - Tried wiggling the individual connectors
- Steffen currently milling final connectors



Grid HV cables

- Need to determine locations to connect cables in each scenario
 - Requires cables of the same length each time
- Got solid works model from Brian and got a primer for how to use solid works from Alden