

Week of 4/17/18

- Following documentation from https://ecolephysique.sciencesconf.org/data/program/G4_LIO_w2_generator_physiclist.pdf

```
/run/initialize

/gun/energy 15 GeV
/gun/particle neutron
/gun/position 0 -.05 .41 m
/gun/number 100
/gun/direction 0 1 0

/gps/particle neutron
/gps/ene/type Mono
/gps/ene/mono 100 MeV
/gps/pos/type Plane
/gps/pos/shape Rectangle
/gps/pos/rot1 0 0 1
/gps/pos/rot2 1 0 0
/gps/pos/halfx 1 m
/gps/pos/halfy 1 m
/gps/pos/centre 0 -.05 .41 m
/gps/direction 0 1 0

/control/verbose 0
/run/verbose 0
/event/verbose 0
/tracking/verbose 0

/ricochetchoozsim/generator/SetNeutronSource true
/ricochetchoozsim/generator/setsourceradius 4.25 m
/ricochetchoozsim/generator/setsourceheight 8.4 m
/ricochetchoozsim/generator/setneutronsourcespectrum fast_neutron_spectrum.txt

/run/beamOn 100
```

GPSPrimaryGeneratorAction.cc

```
#include "G4Event.hh"
#include "G4GeneralParticleSource.hh"

#include "GPSPrimaryGeneratorAction.hh"

GPSPrimaryGeneratorAction::GPSPrimaryGeneratorAction()
{
    m_particleGun = new G4GeneralParticleSource();
}

GPSPrimaryGeneratorAction::~GPSPrimaryGeneratorAction()
{
    delete m_particleGun;
}

void GPSPrimaryGeneratorAction::GeneratePrimaries(G4Event* anEvent)
{
    m_particleGun->GeneratePrimaryVertex(anEvent);
}
```

Error Received

```
[branson3@login04 ChoozSimulation]$ ./RicochetChoozSimulation_build/RicochetChoozSim /afs/hep.wisc.edu/ddm/Ricochet/ChoozSimulation/fast_neutrons_gun.mac
```

```
*****  
Geant4 version Name: geant4-10-01-patch-02 [MT] (19-June-2015)  
Copyright : Geant4 Collaboration  
Reference : NIM A 506 (2003), 250-303  
WWW : http://cern.ch/geant4  
*****
```

```
***** COMMAND NOT FOUND </gps/particle neutron> *****
```

```
***** Batch is interrupted!! *****
```

```
*** Break *** segmentation violation
```

```
=====  
There was a crash.
```

```
This is the entire stack trace of all threads:
```

```
=====  
#0 0x000000329aeac82e in waitpid () from /lib64/libc.so.6  
#1 0x000000329ae3e479 in do_system () from /lib64/libc.so.6  
#2 0x000007f7bab0271b9 in TUnixSystem::StackTrace() () from /afs/hep.wisc.edu/ddm/Ricochet/root_v6.06.08_build/root_v6.06.08/lib/root/libCore.so  
#3 0x000007f7bab02920c in TUnixSystem::DispatchSignals(ESignals) () from /afs/hep.wisc.edu/ddm/Ricochet/root_v6.06.08_build/root_v6.06.08/lib/root/libCore.so  
#4 <signal handler called>  
#5 0x000007f7ba90ca8e0 in G4NeutronHPInelastic::~G4NeutronHPInelastic() () from /afs/hep.wisc.edu/ddm/Ricochet/geant4.10.01.p02/lib64/libG4processes.so  
#6 0x000007f7ba90cb2d9 in G4NeutronHPInelastic::~G4NeutronHPInelastic() () from /afs/hep.wisc.edu/ddm/Ricochet/geant4.10.01.p02/lib64/libG4processes.so  
#7 0x000007f7ba905fbf9 in G4HadronicInteractionRegistry::Clean() () from /afs/hep.wisc.edu/ddm/Ricochet/geant4.10.01.p02/lib64/libG4processes.so  
#8 0x000007f7ba8d55e41 in G4HadronicProcessStore::~G4HadronicProcessStore() () from /afs/hep.wisc.edu/ddm/Ricochet/geant4.10.01.p02/lib64/libG4processes.so  
#9 0x000007f7ba8d5748d in G4ThreadLocalSingleton<G4HadronicProcessStore>::~G4ThreadLocalSingleton() () from /afs/hep.wisc.edu/ddm/Ricochet/geant4.10.01.p02/lib64/libG4p  
rocesses.so  
#10 0x000000329ae35992 in exit () from /lib64/libc.so.6  
#11 0x000000329aeled24 in __libc_start_main () from /lib64/libc.so.6  
#12 0x00000000004229c9 in _start ()  
=====
```

Week of 4/10/2018

- Working on getting interactions in the crystal
- Correct misunderstanding of Geant4 geometries

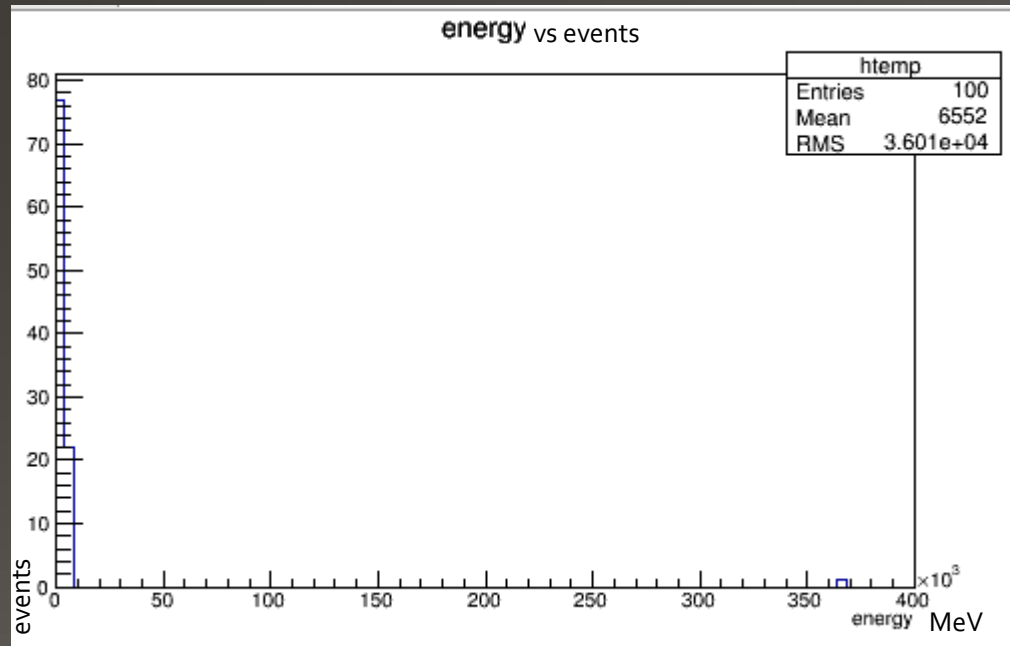

ChoozSimulation with Alex's geometry

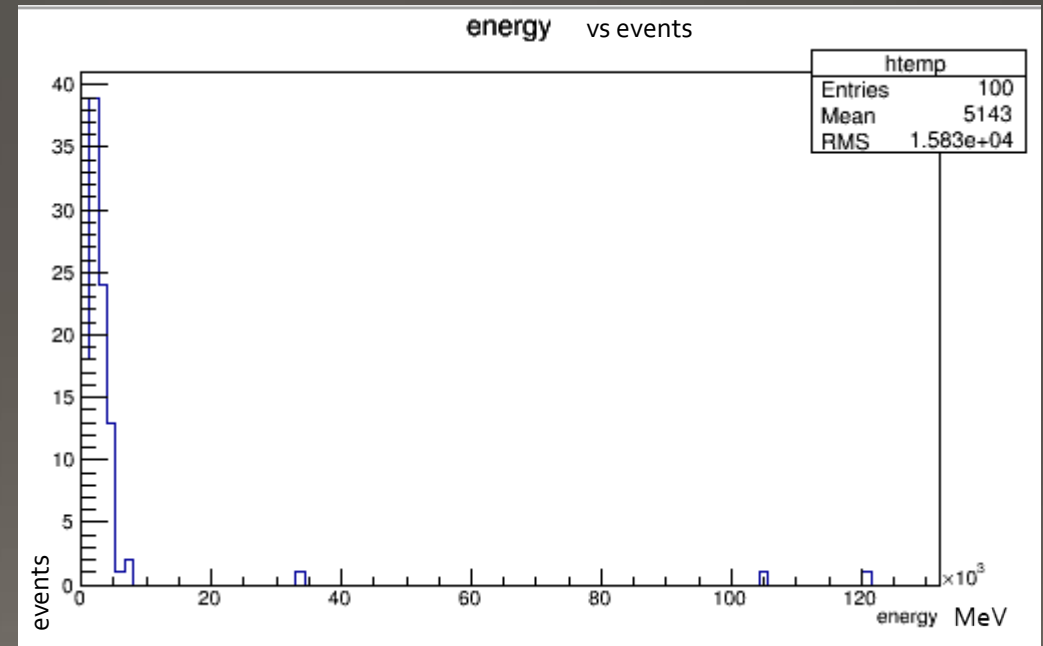

ChoozSimulation with my geometry

Week of 3/13/18

- ChoozSimulation
 - Got it working
 - Using Xming, root crashes when using TBrowser()
 - Will download tool Carolyn uses
- Geometry
 - Finished the geometry file, sent off to Kim, Carolyn, Oliver to look over
 - Check using Oliver's visualization tools

Last Semester

- ADR -> Dilution Refrigerator
 - Created a proposal for a new geometry for a dilution refrigerator
- ChoozSimulation
 - Install geant, root, ChoozSimulation
- Poster
 - Presented at the Women in Physics conference at Iowa State over break

Week of 11/15/2017

- ChoozSimulation
 - Ran into problem with change in login while it was running
 - Was able to get past the problem
 - “Exceeded Disk Quota” at make install
 - We need more space before we can install more
 - Still need to install.... (once we have space)
 - Geant
 - ChoozSim?

ADR -> Dilution Refrigerator

- Relative Geometry is giving me trouble
- Meeting with Oliver to go through and better understand
- Sizes are very different it seems (ADR about 34 cm by 30 cm where Dilution refrigerator is 2.2615 m by 1.15 m)

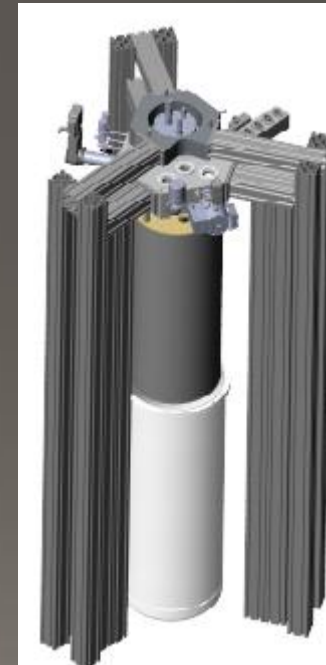
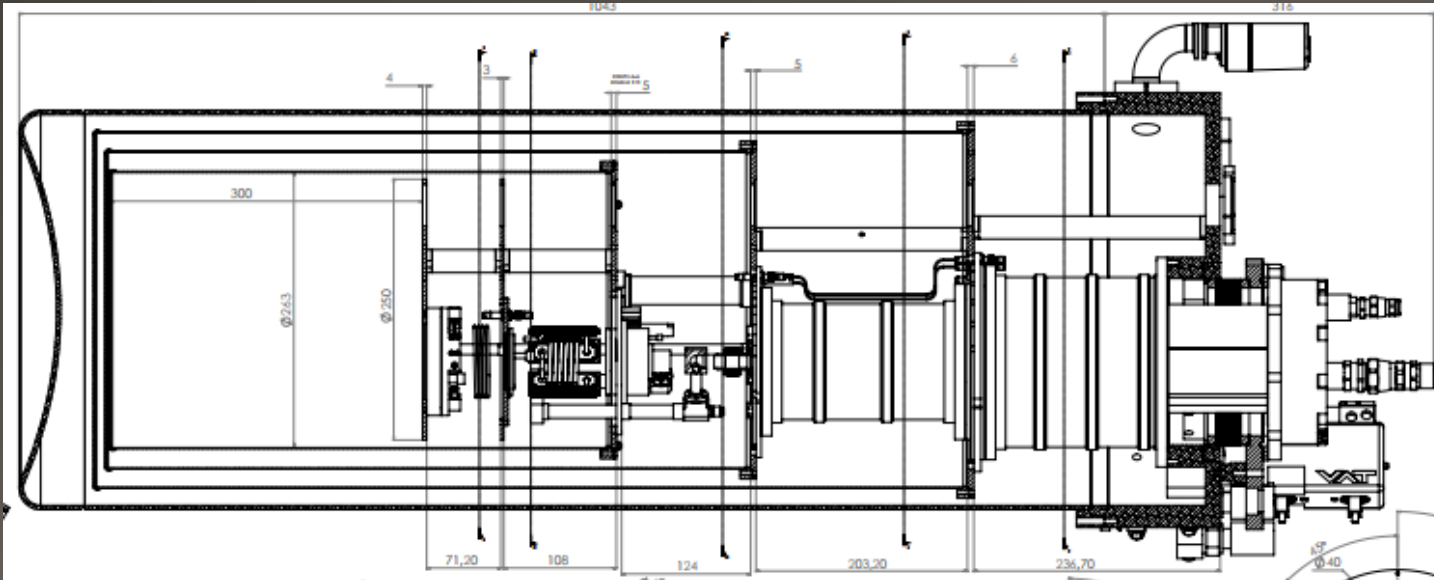

Week of 11/1/2017

- ChoozSimulation
 - After many meetings...
 - It works
 - There would be a histogram for proof if I could login in to the right place

Refrigerators

- ADR (Adiabatic Demagnetization Refrigerator)
 - Magnetic moment aligns with magnetic field
 - Strength of magnetic field \sim strength of alignment
 - Lowering the field slowly to cool
 - Control temp using control of the magnetic field strength

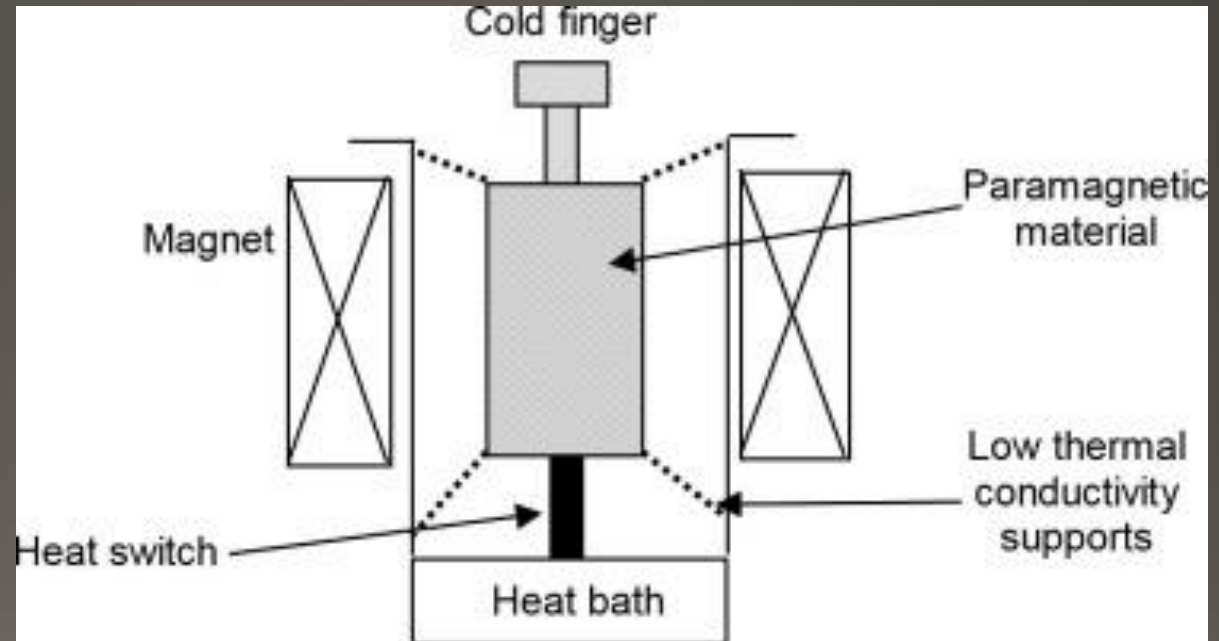

Refrigerators

- Dilution Refrigerator

- .87 Kelvin, He^4 goes to He^3
- First gets sent through a cooling section surrounded by liquid nitrogen
- Through each chamber, pressure goes down, lowering the temperature
- Can go very low (.002 K usually)

Temperature(K)

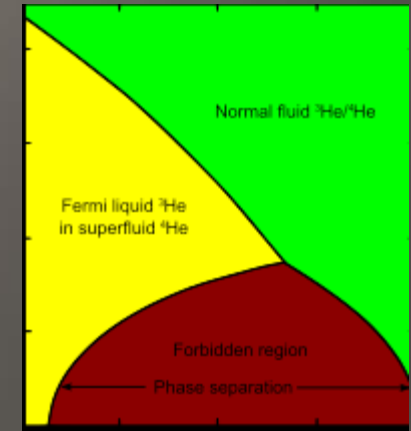

He₃ concentration (%)

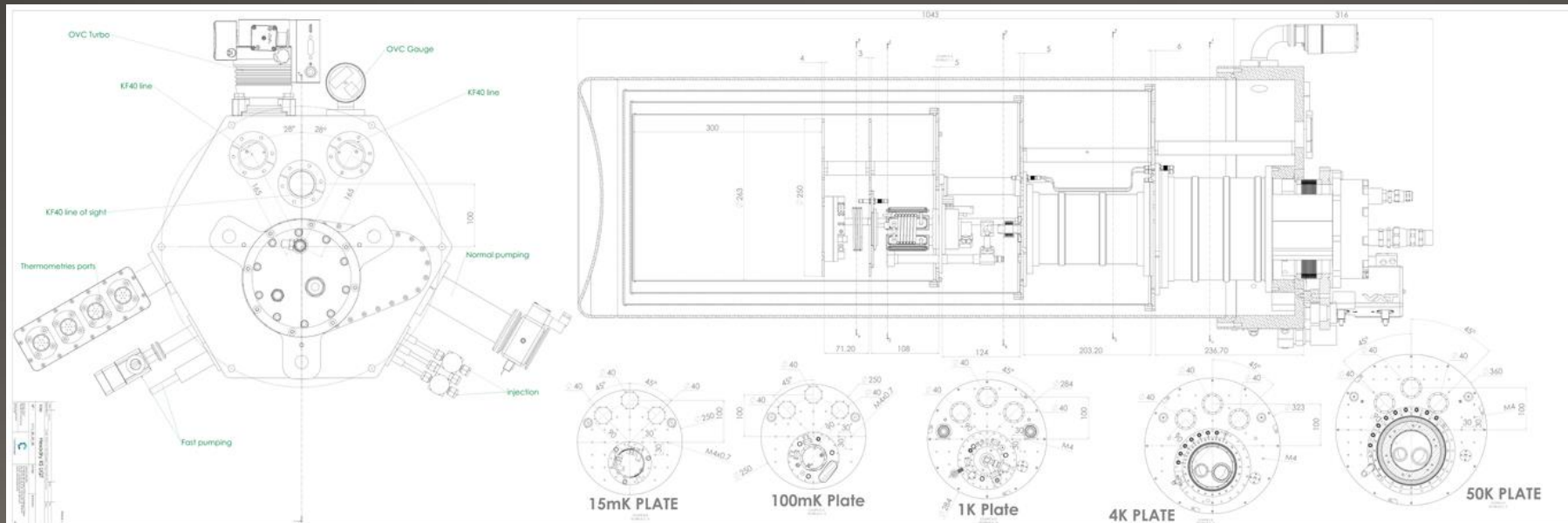

Week of 10/18/2017

- ChoozSimulation
 - Meeting with Dan Bradley tomorrow
 - Recompile ChoozSim
- Geometry files
 - Learning about ADR and Dilution Refrigerators
 - Drawing the Geometry to better visualize a transition

Week of 10/3/17

- Gone last week
- RicochetChoozSim
 - Info from Carolyn
 - Get a segmentation fault
 - Learn about debugging program

Semester Goals Fall 2017

- Get ChoozSimulation working on our computers
- Replace the ADR with a dilution refrigerator in the geometry
- Run the backgrounds with the new geometry
- Run backgrounds finding an exponential rise at the threshold

Summer in Denmark

- Aarhus University
- Ion trapping
- Lasers
- Calculations for MgH^+

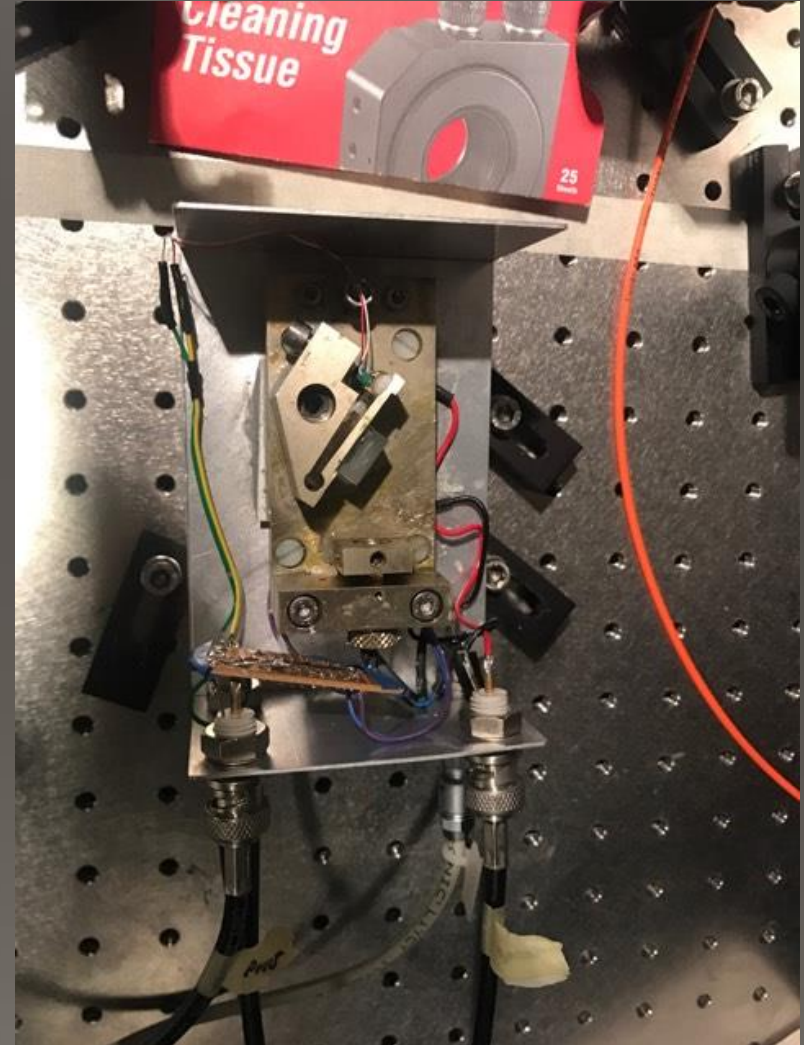

Replacing the ADR

Outer
Detector, [1
m, 4.25 m] x
[3.2 m, 4.2 m]

Pb and
Polyethylene, 4
cm and 10cm

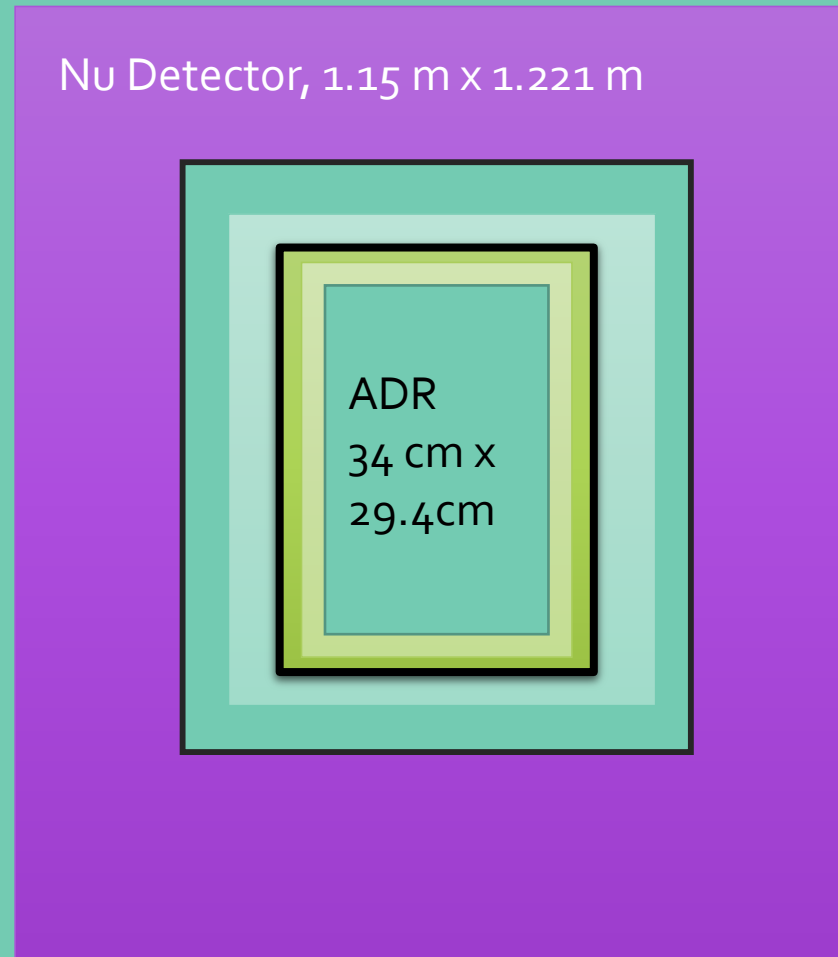

Overall Project

I am working with Ricochet and will be doing simulations of the neutron background being received in the detector.

Week of 5/23

- Trouble with the unzipped ChoozSimulation
- Try to get git clone working with github.mit.edu to acquire the
- Getting help with our github.mit.edu problems
 - Talking to Alex and trying to figure out why it wasn't working
 - Lead to creating ssh keys that did not work
 - Call MIT help desk
 - So far they have been unable to help
 - Alex was able to get the github working on our computers, but through a vncserver, not through a ssh pipe

Spring Semester 2017

Started:

- We have moved closer to being able to do simulations in our new directories with our new code and the new information that comes with that.
- Over the summer Carolyn and Kim will move on, I will work with them for about 3 more weeks.

Learned:

- About linux and more about these simulations
- About Ricochet, what it is doing and some of the parts that go into building it.

Week of 5/2

Goals:

- Create an environment so that I can move forward with installing the ChoozSimulation code
- Get the installation finished off with hopefully no more problems.

Completed:

- Made an env.sh that seems to work and has brought me to the next part of the install of ChoozSimulation code.
- The testCfneutrons.mac works in the new (ratcage-040317) directory

Week of 4/25

Goals:

- Install the ChoozSimulation code into the new directory and build it
- Have the testCfneutrons.mac run in the old directory and new directory to make sure everything is working

Completed:

- The MATERIALS.ratdb is now as it should be and working
- Downloaded the ChoozSimulation after having trouble transferring it from github to the server

Week of 4/18

Goals:

- Install ChoozSimulation code into the new Ricochet directory and try and build it
- Fix typos in MATERIALS.ratdb

Completed:

- Transfer from old SPECTRUM.ratdb and adding additional elements to ELEMENTS.ratdb from old directory (ratcage) to new directory (ratcage-040317)

Week of 4/11

Goals:

- Transfer old spectrum, needed materials and elements over from old rat folder into the new rat folder, where the simulations will be done from now on.