

# DOE REVIEW

---

Wisconsin at ATLAS



*Sau Lan Wu*



For the Task H and Task H-1 (Wu)

*August 26, 2010*

# OUTLINE

At the request of Associate Professor Pan and Assistant Professor Mellado, Task H is split into two independent tasks:

Task H – 1 (Wu)

Task H – 2 (Pan and Mellado)

Separation in research since March/April 2010

# OUTLINE

## PART 1

- (1) LHC Physics with data since April 2010 *Task H-1 (Wu)*
- (2) Manpower and University Contribution *Task H-1 (Wu)*
- (3) Near term physics goals (FY11-13) *Task H-1 (Wu)*
- (4) **Our contribution in detector and services – present and future** *Task H-1 (Wu)*  
*(presented by Assistant Scientist Luis Flores)*

# OUTLINE

## PART 2

- (1) **ATLAS notes with Data** *Task H-2 (Mellado, Pan)*
- (2) **Progress report of the past 3 years** *Task H ( All )*  
(2007 to March 2010) *( Mellado, Pan, Wu)*

**Contribution and future plans for hardware will be covered by B.Mellado**

**Future plans for physics analysis will be covered by Y.Pan**

Muon Spectrometer ( $|\eta| < 2.7$ ) : air-core toroids with gas-based muon chambers  
Muons trigger and measurement with momentum resolution  $< 10\%$  up to  $E_\mu \sim 1$  TeV

Length :  $\sim 46$  m  
Radius :  $\sim 12$  m  
Weight :  $\sim 7000$  tons  
 $\sim 10^8$  electronic channels  
3000 km of cables

3-level trigger  
reducing the rate  
from 40 MHz to  
 $\sim 200$  Hz

Inner Detector ( $|\eta| < 2.5, B=2T$ ):  
Si Pixels, Si strips, Transition  
Radiation detector (straws)  
Precise tracking and vertexing,  
 $e/\pi$  separation  
Momentum resolution:  
 $\sigma/p_T \sim 3.8 \times 10^{-4} p_T (\text{GeV}) \oplus 0.015$

EM calorimeter: Pb-LAr Accordion  
 $e/\gamma$  trigger, identification and measurement  
E-resolution:  $\sigma/E \sim 10\%/\sqrt{E}$

**HAD calorimetry ( $|\eta| < 5$ ): segmentation, hermeticity**  
**Steel/scintillator Tiles (central), Cu/W-LAr (fwd)**  
**Trigger and measurement of jets and missing  $E_T$**   
**E-resolution:  $\sigma/E \sim 50\%/\sqrt{E} \oplus 0.03$**

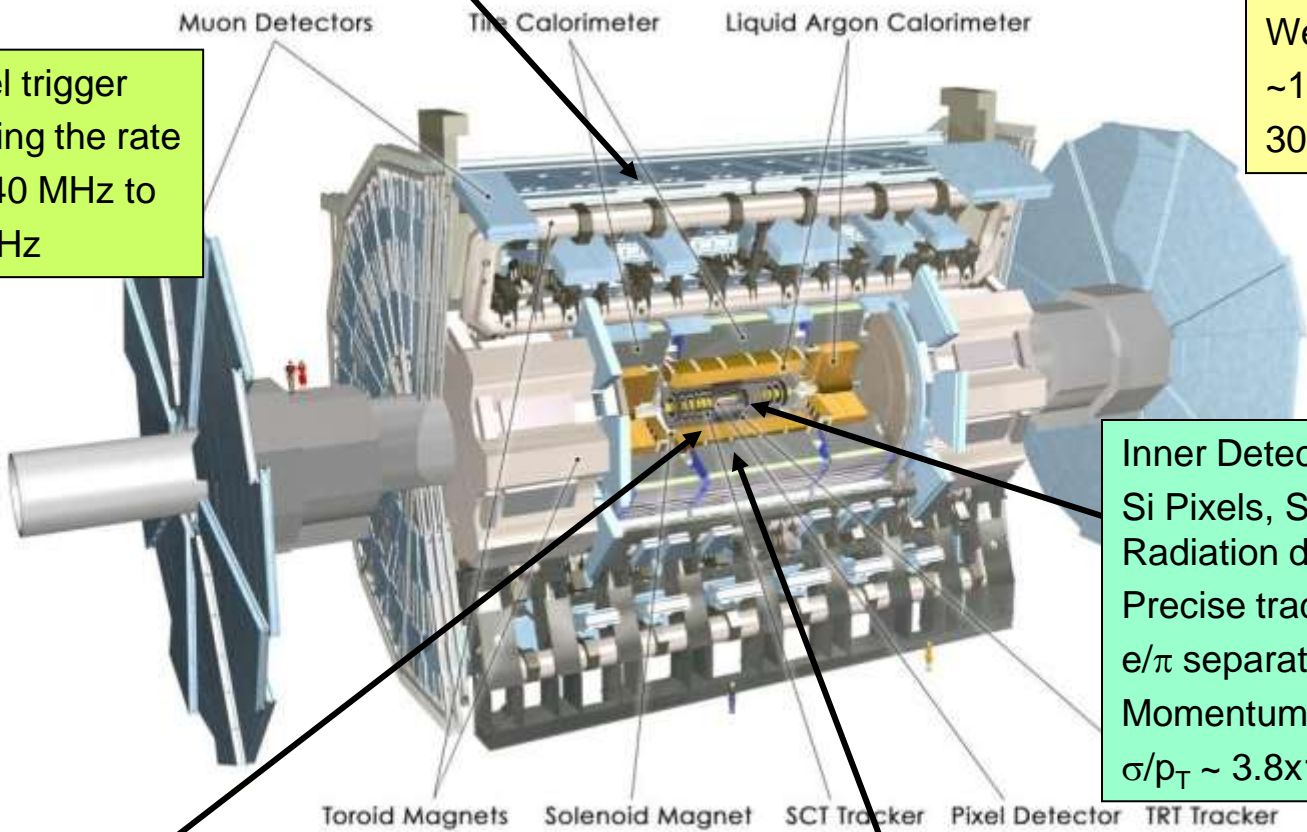

LHC Physics with data  
since April 2010 *TASK H-1 (Wu)*

*Contribution to physics results for summer conferences*

# FOR THE FIRST TIME WITH ATLAS DATA

I started in ATLAS in **1993**; for 16 years I have stood at exactly this place telling the DOE reviewers about

- our Silicon Readout Driver effort,
- our High Level Trigger effort,
- our software development effort,
- our physics preparation with MonteCarlo data.

***This is an emotional day for me: after 16 years of preparation, I can show you for the first time results from data. Our hard work begins to bear fruit.***

## Update since written proposal, April 2010 LHC physics results on data

I am reporting here first only on the work of **TASK H-1 (Wu)**.

Since the completion of the DOE write-up in April for this review, our group has made important contributions to **20 results on data (conference notes)** and 5 public notes on Monte Carlo studies for the summer conferences

*(Results shown here which intend for conferences in September are work in progress. Please treat them confidential)*

**Physics at the LHC 2010 (PLHC)**

DESY, Hamburg, June 7-12

**ICHEP 2010.**

Paris, July 22-28

**Hadron Collider Physics 2010 (HCP)**

Toronto, August 23-27

**SUSY 10.**

Bonn, August 23-28

**Physics in Collision 2010 (PIC)**

Karlsruhe, Sep1-4

**ISMD 2010\***

Antwerp, Belgium Sep 21-25

# Update since written proposal, April 2010

## LHC physics results on data

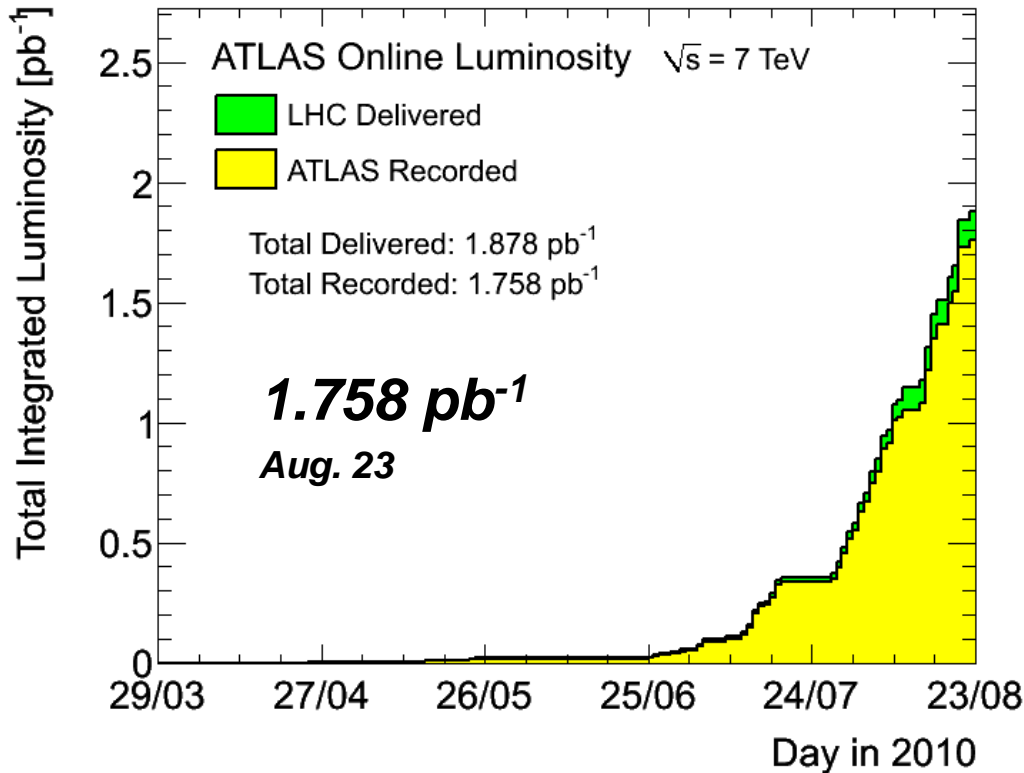

### Peak luminosity

$$9 \times 10^{30} \text{ cm}^{-2} \text{ s}^{-1}$$

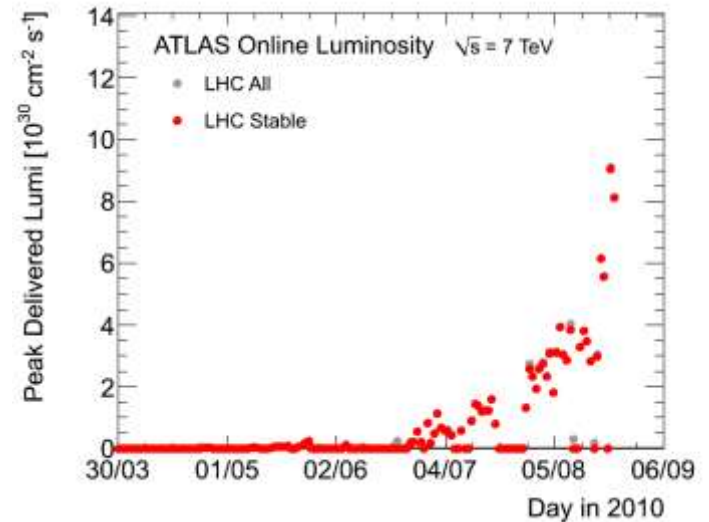

- First collisions at 7 TeV on March 30, 2010
- 3 orders of magnitude luminosity improvement in 5 months
- For ICHEP, at  $\sim 330 \text{ nb}^{-1}$  (Expected : end of 2011: **1 fb<sup>-1</sup>**)

# **Contribution to physics results for summer conferences**

## **LHC physics results on data *TASK H-1 (Wu)***

***Our group TASK H-1 has contributed significantly to the following 25 results (20 results from data) for summer conferences. In each physics result, we fully collaborate with other ATLAS institutions.***

- **Detector Performance** (5 conference notes)
- **Physics with Jets** (5 conference notes)
- **W, Z, Z+jets and W'** (5 conference notes)
- **Physics with Photons** (2 conference notes)
- **SUSY** (1 conference notes)
- **Higgs** (2 conference notes)
- **Public notes** contribution to conferences with MC results (5 notes : 2 in SUSY, 1 in W'/Z', 2 in Higgs)

# Detector performance

***S. L. Wu, Postdocs Fang, Ma, Quayle, Sarangi,  
Grad. Student Wang***

1. Performance of the ATLAS electromagnetic calorimeter for  $\pi^0$  to  $\gamma\gamma$  and  $\eta$  to  $\gamma\gamma$  events
2. Performance of the missing transverse energy reconstruction in minimum bias events at  $\sqrt{s}$  of 900 GeV and 2.36 TeV
3. Performance of the missing transverse energy reconstruction in minimum bias collisions at center-of-mass energy of  $\sqrt{s} = 7$  TeV with the ATLAS detector
4. Performance of the Missing Transverse Energy Reconstruction and Calibration in  $pp$  Collisions at  $\sqrt{s} = 7$  TeV
5. Performance of the ATLAS Jet Trigger in the Early  $\sqrt{s} = 7$  TeV Data.

## Conf note 1 : Performance of the ATLAS electromagnetic calorimeter for $\pi^0$ to $\gamma\gamma$ and $\eta$ to $\gamma\gamma$ events (PLHC 2010, DESY)

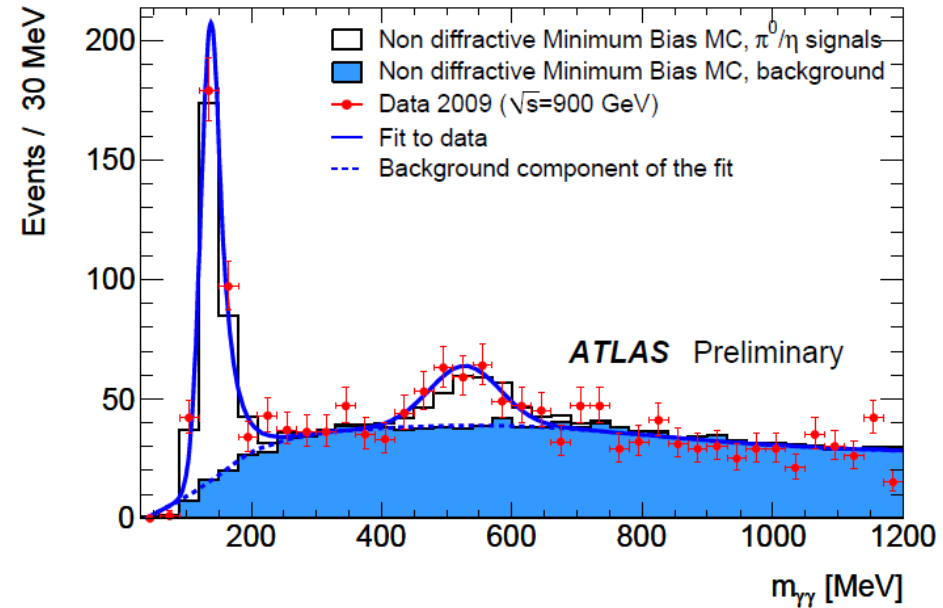
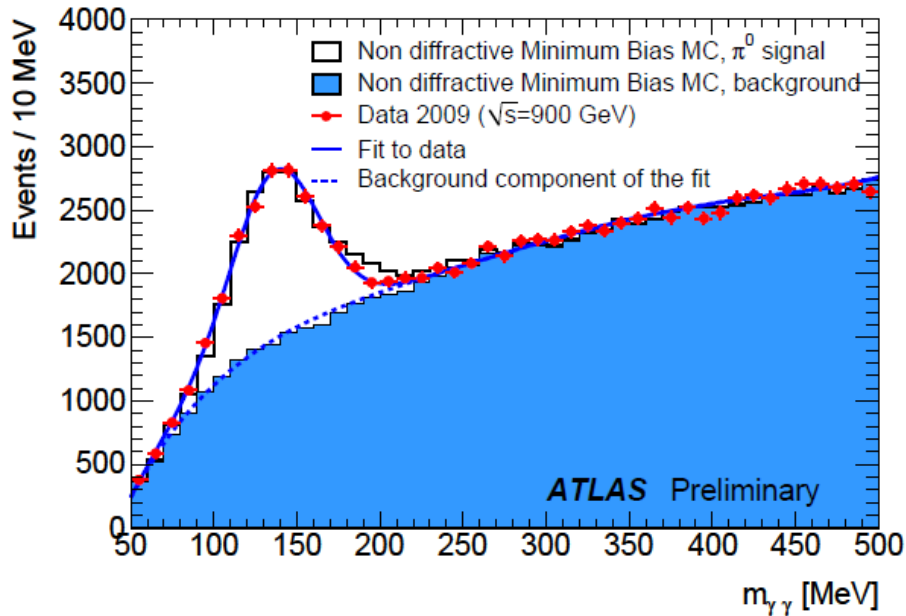

- **First collision data**, at  $\sqrt{s} = 900$  GeV
- $\pi^0$  and  $\eta$  are reconstructed from diphotons
- With this sample, the response uniformity along the pseudo-rapidity was shown to be **better than  $\pm 2\%$**
- Our contribution: **event selection, photon calibration**

**Conf note 2 : Performance of the missing transverse energy reconstruction in minimum bias events at  $\sqrt{s}$  of 900 GeV and 2.36 TeV (PLHC 2010, DESY)**

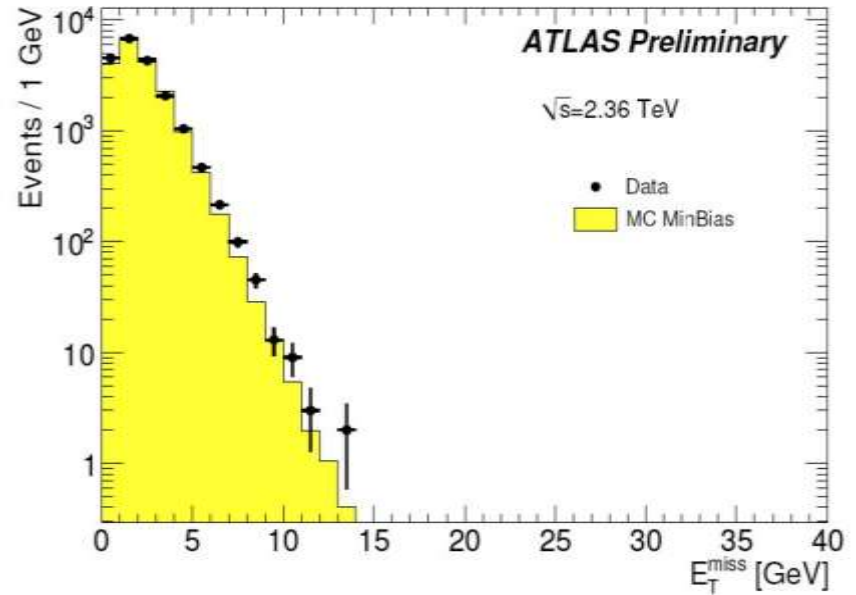
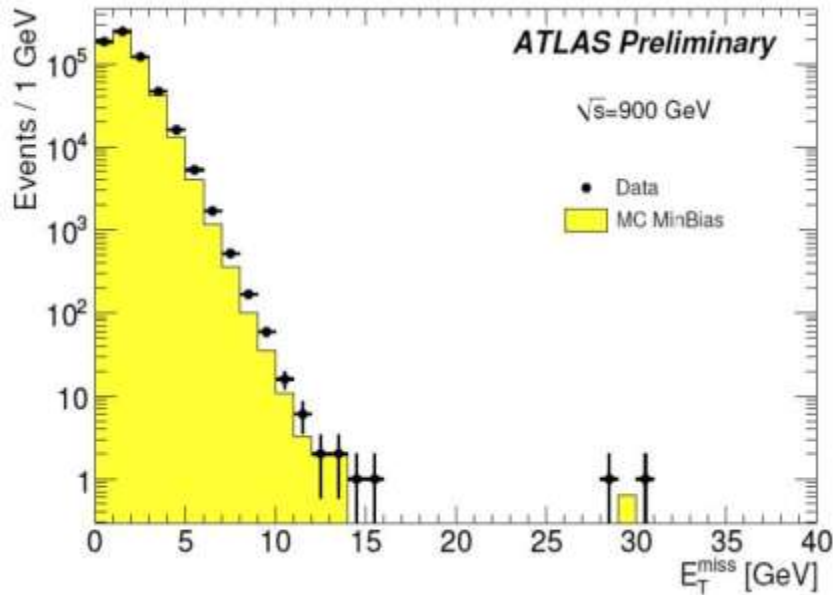

- First collision data at  $\sqrt{s}$  of 900 GeV and 2.36 TeV
- Our contributions: algorithm development and study of the performance of the missing transverse energy and investigate events with high  $E_T^{\text{miss}}$

**Conf note 3 : Performance of the missing transverse energy reconstruction in minimum bias collisions at center-of-mass energy of  $\sqrt{s} = 7$  TeV with the ATLAS detector (PLHC 2010, DESY)**

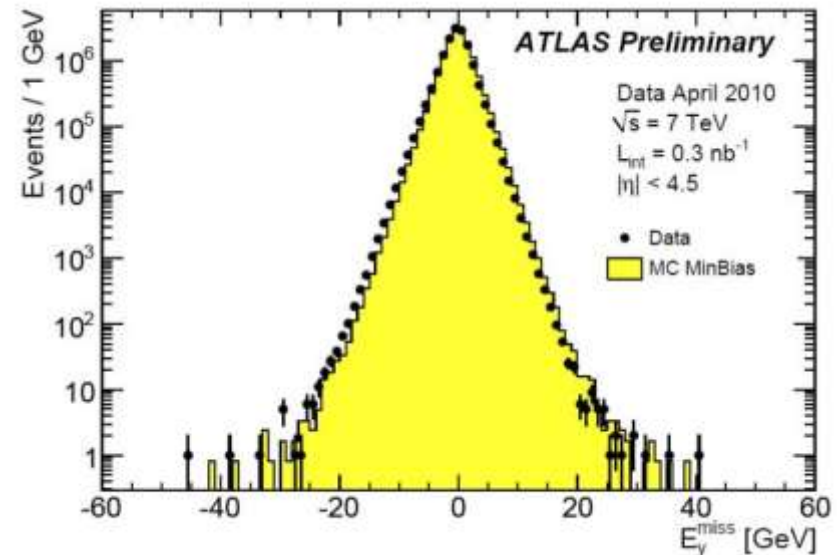
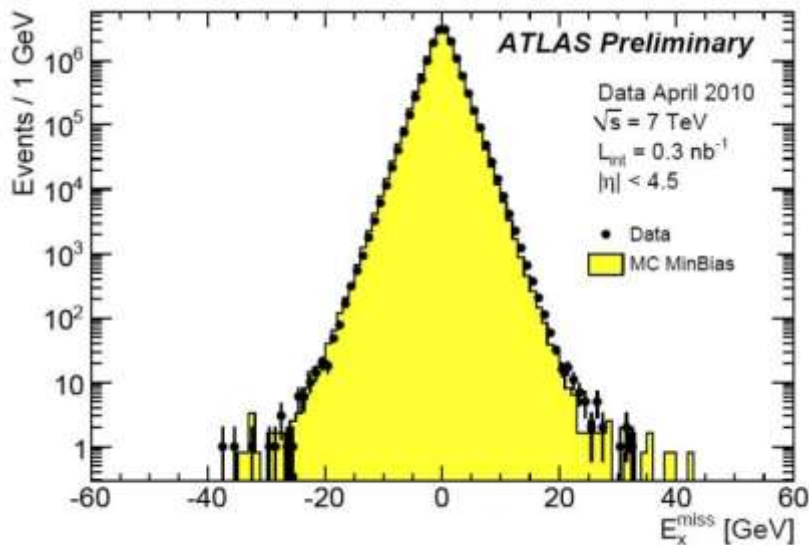

- First collision data at  $\sqrt{s}$  of **7 TeV**
- Our contributions : studying the performance of the missing transverse energy and checking all the components used for the  $E_T^{miss}$  calculation. Conclude that the  $E_T^{miss}$  tail mainly comes from the muon term.

**Conf note 4: Performance of the Missing Transverse Energy Reconstruction and Calibration in pp Collisions at  $\sqrt{s}=7$  TeV (ICHEP 2010, Paris)**

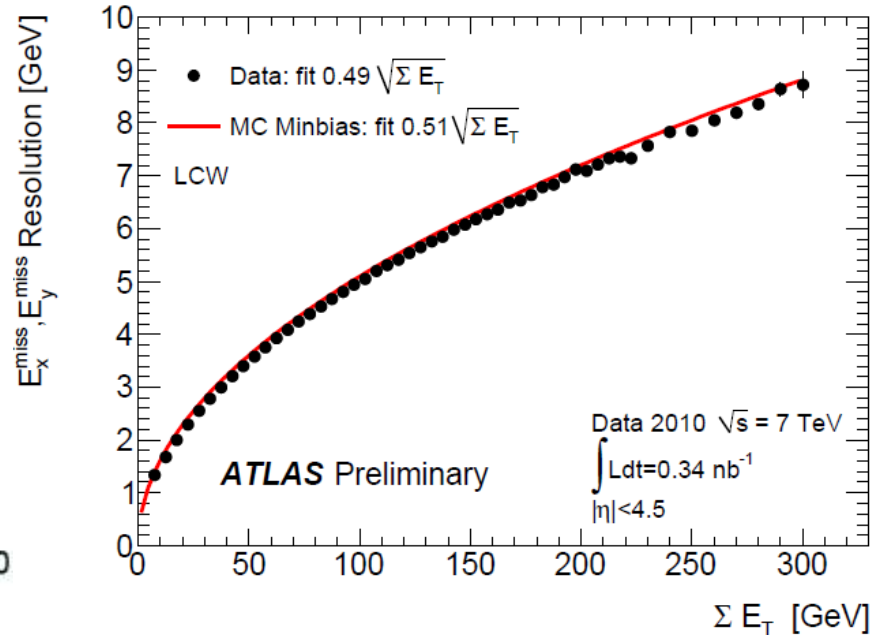
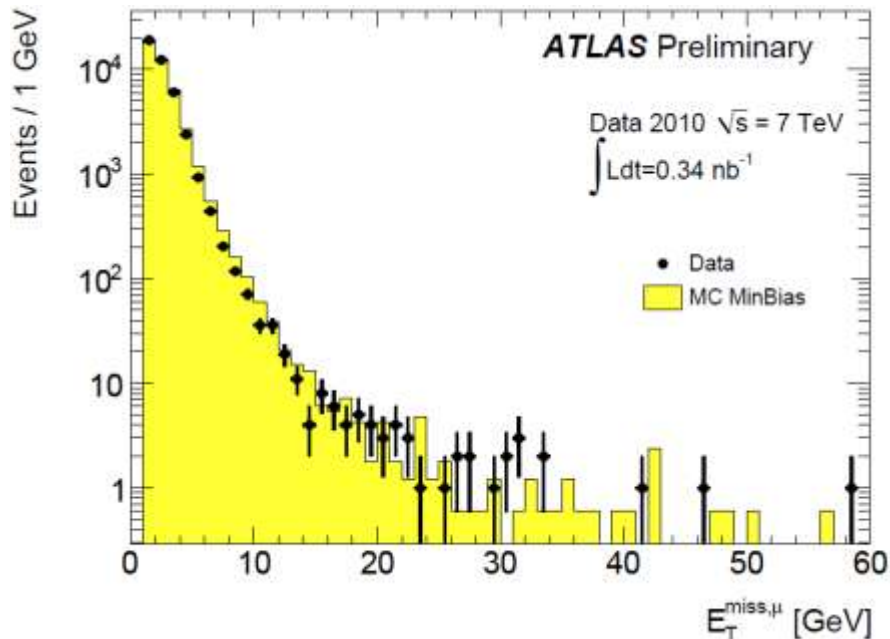

**Our contributions:**

- Propose a set of cleaning cuts on muons used in the reconstruction of Missing Transverse Energy.
- Study the resolution of Missing Transverse Energy with different calibration schemes.

## Conf note 5 : Performance of the ATLAS Jet Trigger in the Early $\sqrt{s} = 7$ TeV Data (ICHEP 2010, Paris)

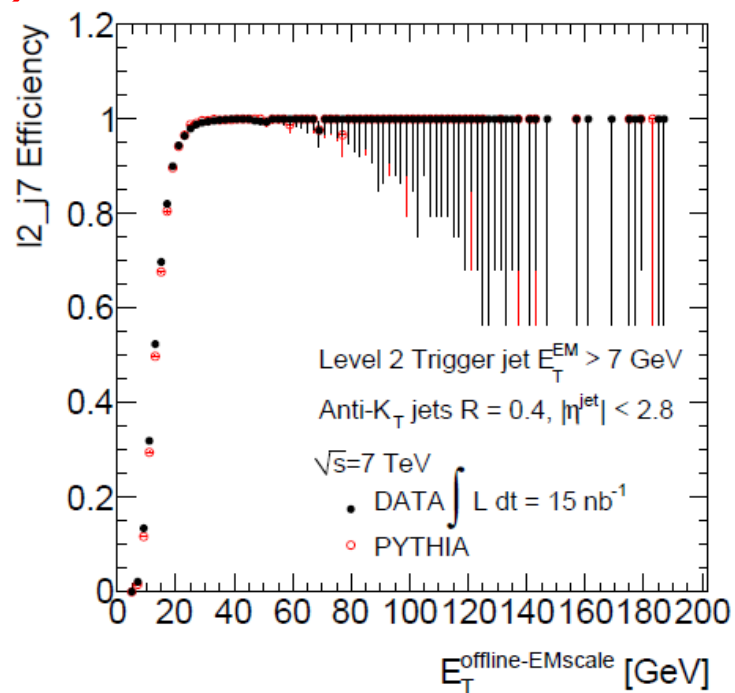
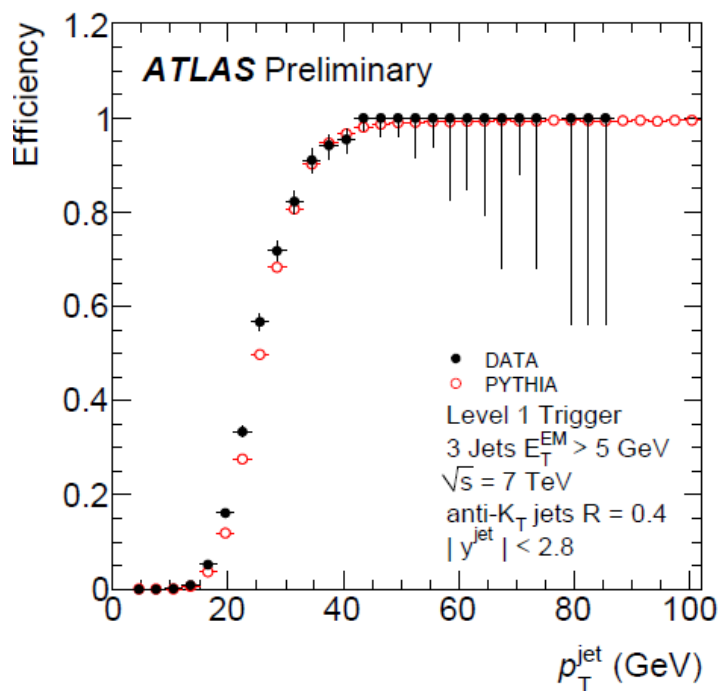

- Jet trigger studies with early data at 7TeV
- Good data/MC agreement at both L1 and L2 (in pass-through mode)
- Our contribution: development and validation of the trigger monitoring framework

Physics results from first data since April 2010 **TASK H-1 (Wu)**

## Physics with jets

***S. L. Wu, Postdocs Peng, Poveda, Sarangi,  
Grad. Students A. Castaneda, Ji, Li***

6. Measurement of jet production in 7 TeV pp collisions with the ATLAS detector
7. Measurements of multijet production cross sections in pp collisions at 7 TeV
8. Search for new particles decaying into dijets in pp collisions at  $\sqrt{s}=7$  TeV
9. High-pT dijet angular distributions in pp interactions at  $\sqrt{s}=7$  TeV
10. Search for new physics in multi-body final states at high invariant masses

# PHYSICS WITH JETS

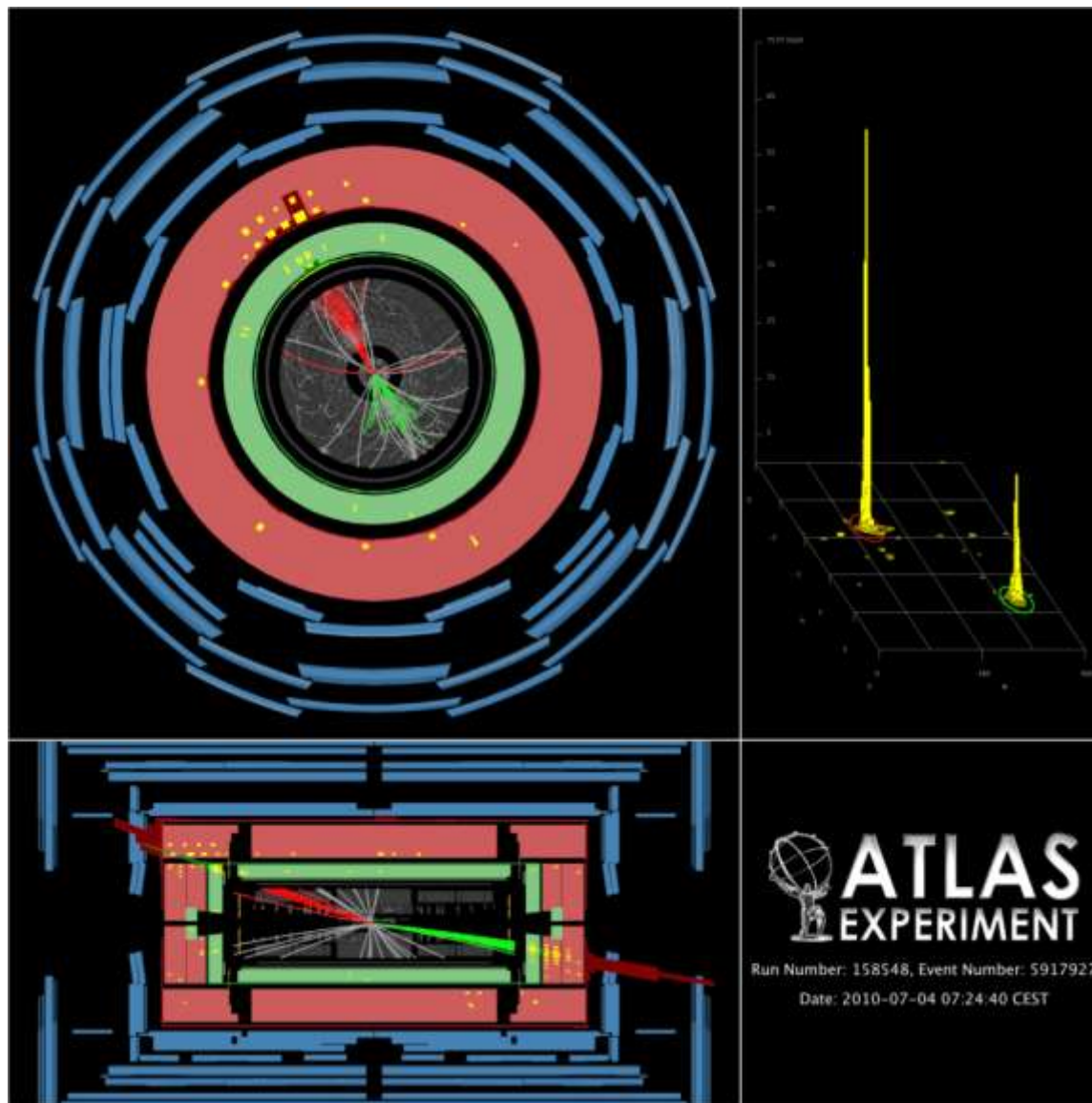

Highest  $m_{jj}$  dijet  
event observed  
for ICHEP  
 $m_{jj}=2.55\text{TeV}$ .  
 $p_T^{j1}=420\text{GeV}$ ,  
 $p_T^{j2}=320\text{GeV}$

**Conf note 6 : Measurement of jet production in 7 TeV proton-proton collisions with the ATLAS Detector (ICHEP 2010, Paris)**

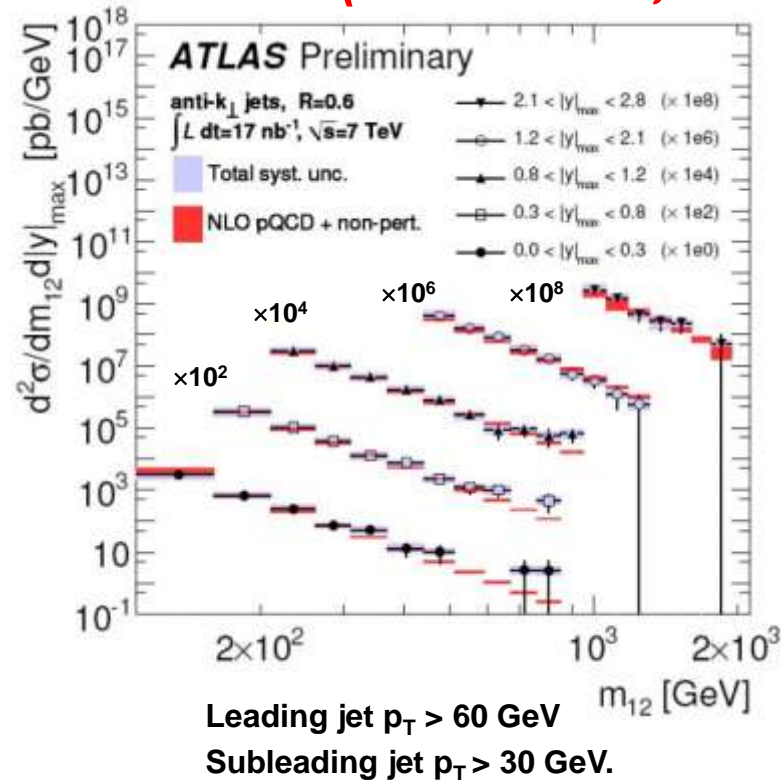
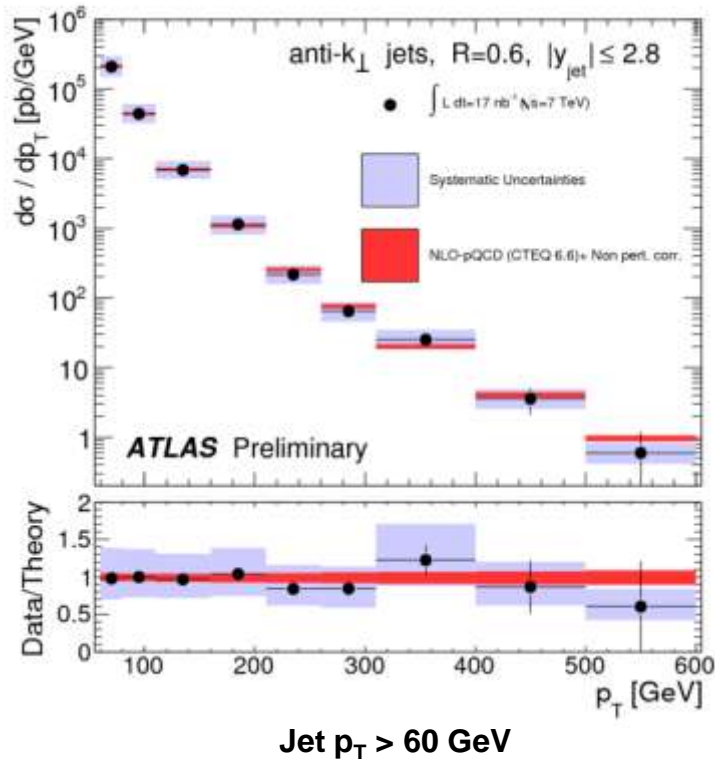

- First inclusive jet and dijet cross sections measurement in ATLAS
- The cross sections extend up to jet  $p_T$  of 500 GeV and  $M_{ij}$  of 2 TeV
- Good agreement with NLO QCD expectation over 5 orders of magnitude

*updated to 1 pb<sup>-1</sup>*

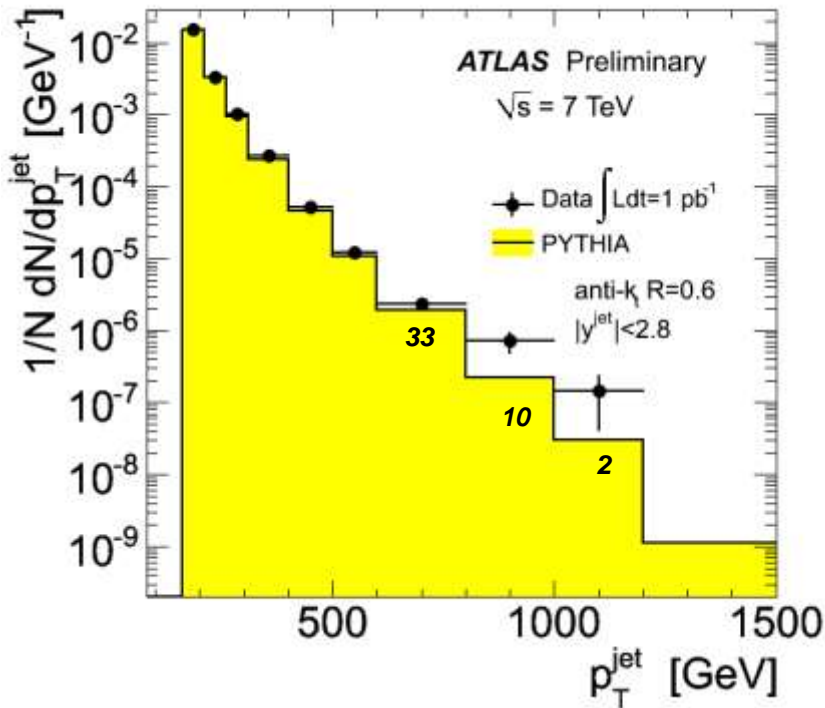

**Jet  $p_T > 160 \text{ GeV}$**

69568

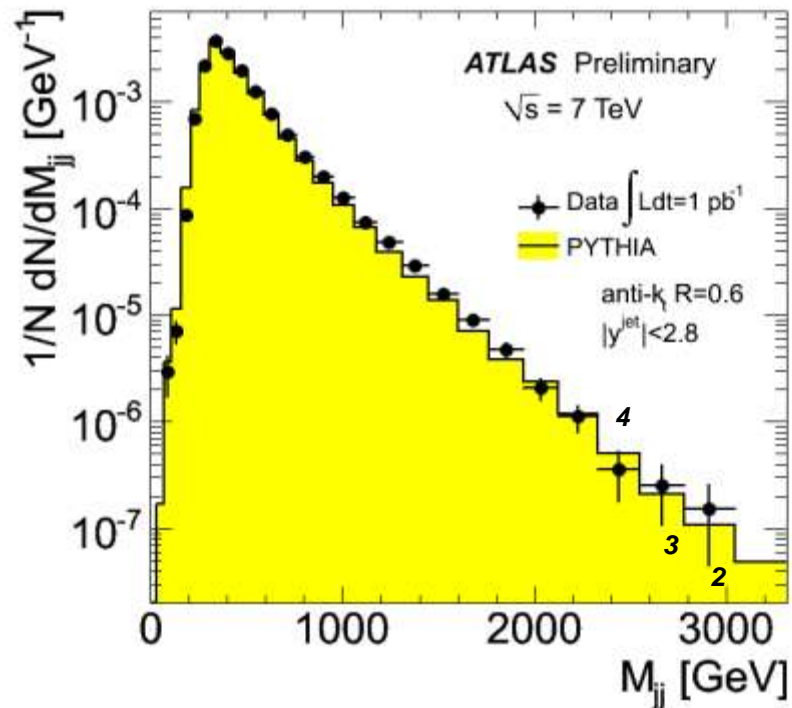

**Leading jet  $p_T > 160 \text{ GeV}$   
 Subleading jet  $p_T > 40 \text{ GeV}$ .**

51253

**Conf note 7 : Measurements of multijet production cross sections in proton-proton collisions at 7 TeV center-of-mass energy with the ATLAS Detector (HCP 2010, Toronto)**

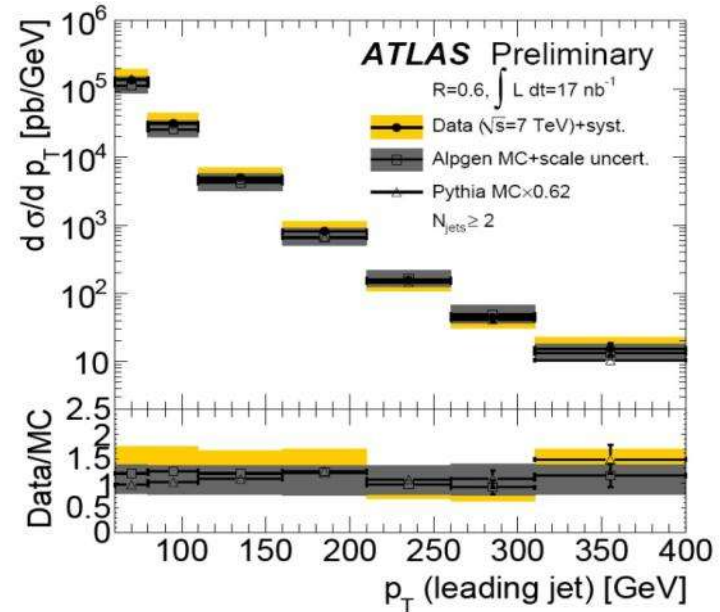
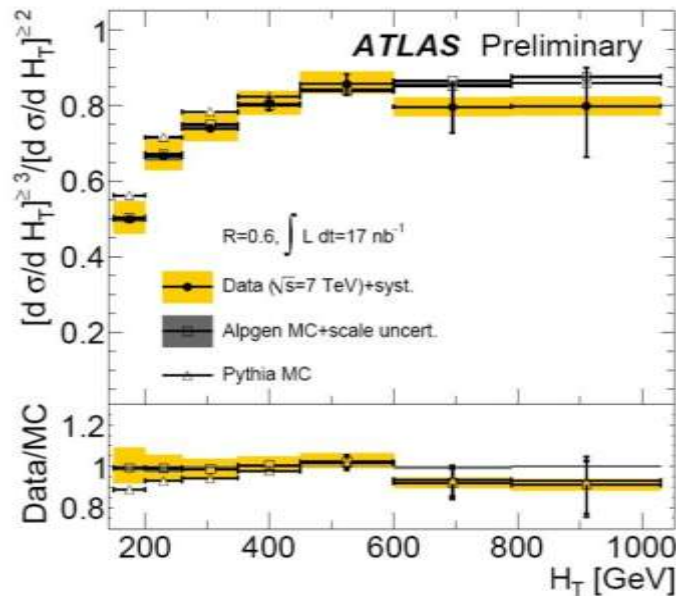

- Differential cross sections of 1<sup>st</sup>, 2<sup>nd</sup>, 3<sup>rd</sup> and 4<sup>th</sup> leading jets
- Ratio of differential cross sections as a function of  $H_T$  for events  $\geq 3$  jets and events  $\geq 2$  jets
- Good agreement with LO QCD expectation

$$H_T = \sum_{\text{jets}} p_T$$

**Conf note 8 : Search for new particles decaying into dijets in pp collisions at  $\sqrt{s}=7\text{TeV}$  (ICHEP 2010)**

Signature of excited quark:

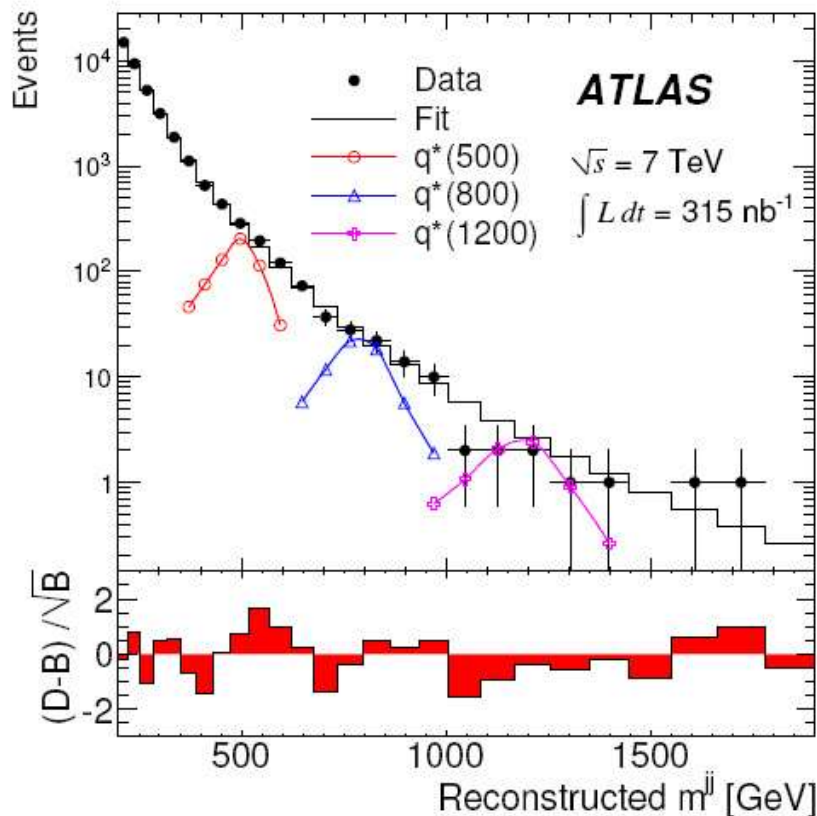

Signal acceptance :

Range from

$\sim 36\%$  for  $m_{q^*} = 400 \text{ GeV}$

( $\sigma_{m_{jj}}/m_{jj} \sim 11\%$ )

to

$\sim 49\%$  for  $m_{q^*} = 1.5 \text{ TeV}$

( $\sigma_{m_{jj}}/m_{jj} \sim 7\%$ )

New state: Excited quark  $q^*$

• U. Baur, I. Hinchliffe, and D. Zeppenfeld, *Int. J. Mod. Phys., A2*, 1285 (1987)

• U. Baur, M. Spira, and P. M. Zerwas, *Phys. Rev., D42*, 815 (1990)

**Conf note 8 : Search for new particles decaying into dijets in pp collisions at  $\sqrt{s}=7\text{TeV}$  (ICHEP 2010, Paris)**

Limit on  $q^*$  production

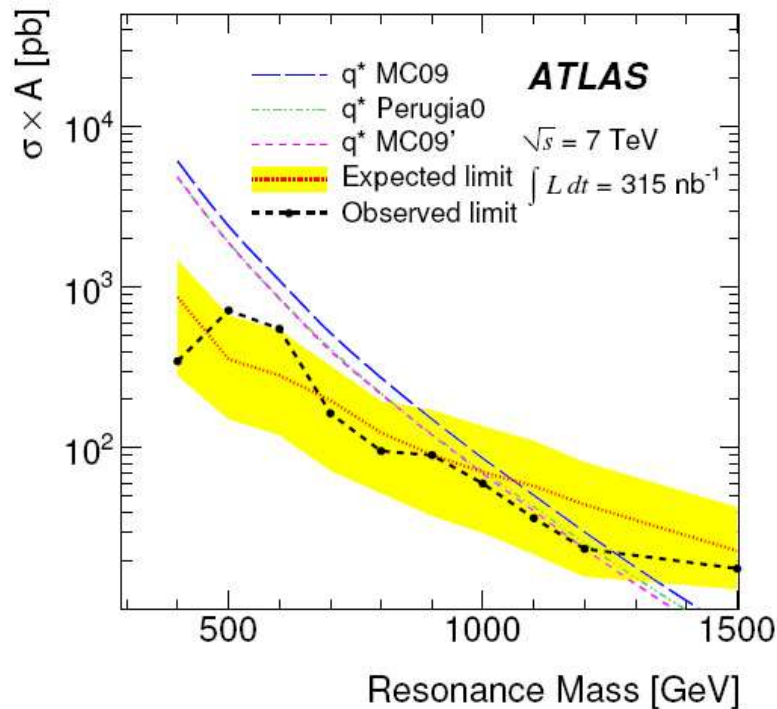

**Excluded at 95% CL:**

With MRST PDF:  
 (Martin, Roberts, Stirling, Thorne)

**$400 < m_{q^*} < 1260 \text{ GeV}$**   
 with  $315 \text{ nb}^{-1}$

Latest published limit:

**$260 < m_{q^*} < 870 \text{ GeV}$**   
 with  $1.1 \text{ fb}^{-1}$

CDF Collaboration,  
 Phys.Rev.D 79(2009)112002

- **First search result on new physics from ATLAS**
- **We are now moving into unexplored territory**
- **Submitted for publication (PRL) on Aug. 13, 2010**

**Conf note 9 : High- $p_T$  dijet angular distributions in  $pp$  interactions at  $\sqrt{s} = 7$  TeV measured with the ATLAS detector at the LHC (ICHEP 2010, Paris)**

- Search for deviations from QCD via angular distributions
- High- $p_T$  dijets: QCD: mainly t-channel; new physics: s-channel.

**Observable (at high  $m_{jj}$ )**

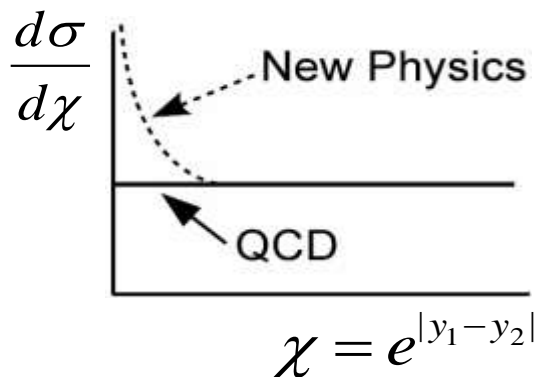

The choice of  $\chi$  is motivated by the fact that the lowest-order QCD cross section is independent of  $\chi$  (distorted by radiative correction)

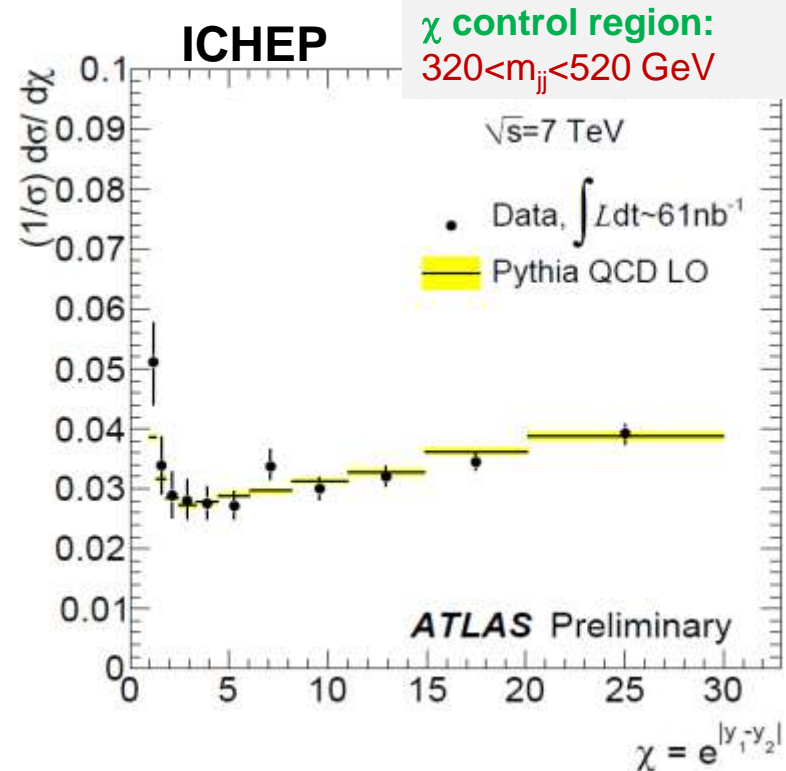

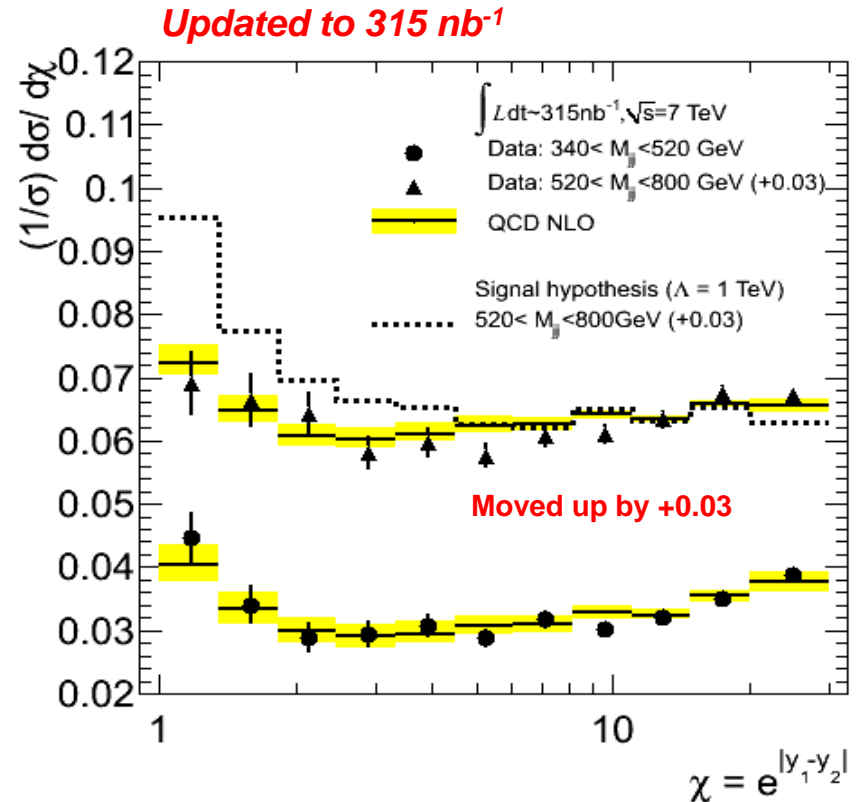
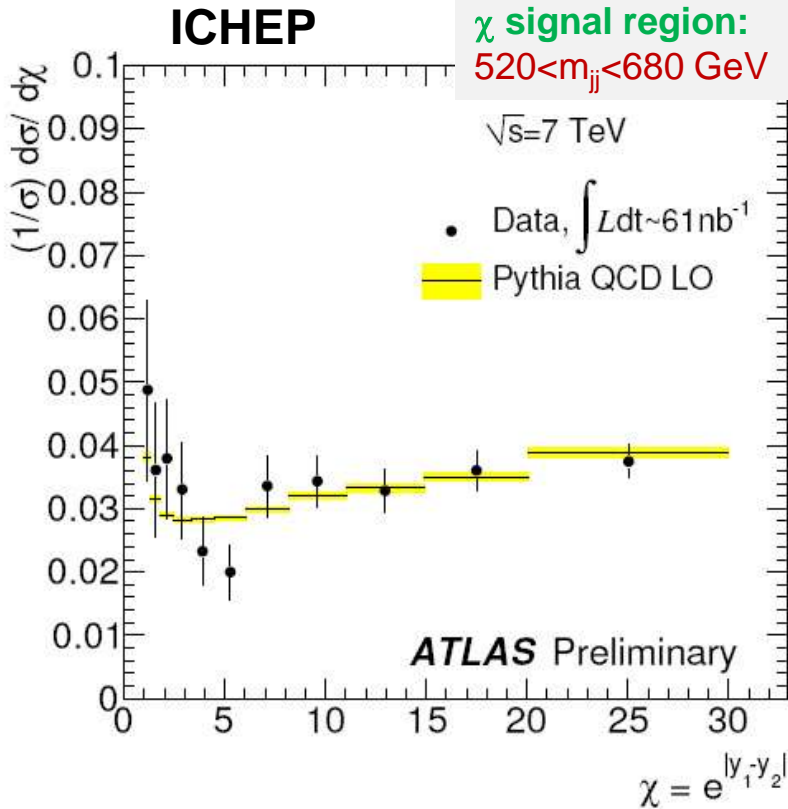

**Limit on quark contact interaction :**  
 $\Lambda > 875$  GeV (61 nb<sup>-1</sup>) for ICHEP 2010

**This corresponds to :  $2.3 \times 10^{-4}$  fm**

Latest published limit (DØ Collaboration) :

$\Lambda > 2.8$  TeV (0.7 fb<sup>-1</sup>)

Phys.Rev.Lett.103:191803,2009

Effective Lagrangian for four-quark contact interaction model

$$L_{qqqq}(\Lambda) = \frac{\eta g^2}{2\Lambda^2} \bar{\Psi}_q^L \gamma^\mu \Psi_q^L \bar{\Psi}_q^L \gamma^\mu \Psi_q^L \quad (\eta=+1)$$

Larger  $\Lambda$  corresponds to weaker four-quark contact interaction

**Conf note 10 : Search for new physics in multi-body final states at high invariant masses (HCP 2010, Toronto)**

**Motivation : Look for signature of large multiplicity, high transverse energy and large invariant mass.**

**Inspired by : Black Hole and String Ball signatures.**

- Search for deviations from the SM with final state topologies of large multiplicity, high total transverse energy of decay products and large invariant mass( **Black Hole signature** ) .
- These multi-body topologies may be evidence of scenarios of low scale gravity from gravitationally mediated interactions.
- The **electroweak scale** and the **Planck scale** ( $\sim 10^{18}\text{GeV}$ ), at which gravitational interactions become strong, differ by  $\sim 16$  orders of magnitude
- This can be addressed by gravity **expanding into extra dimensions**, while the SM particles are confined to our familiar 4D space
- For large extra dimensions, the fundamental scale of gravity can be as low as the electroweak scale and black holes can be produced at the LHC

**Conf note 10 : Search for new physics in multi-body final states at high invariant masses (HCP 2010, Toronto)**

## **Black holes vs String balls**

- The Black Hole mass is expected to be **greater 5 TeV**; at  $\sqrt{s}=7\text{TeV}$ , the production cross section is small
- In string theory, black holes have a minimum mass below which they transition into highly excited long and jagged strings – “string balls”
- Because they are lighter, they may be more accessible to the LHC. String balls have the same signature as Black Hole.
- Our **multi-body analysis strategy** can be used for the search for string balls; Its cross section can be large enough for discovery even with  $O(10 \text{ pb}^{-1})$

**Conf note 10 : Search for new physics in multi-body final states at high invariant masses (HCP 2010, Toronto)**

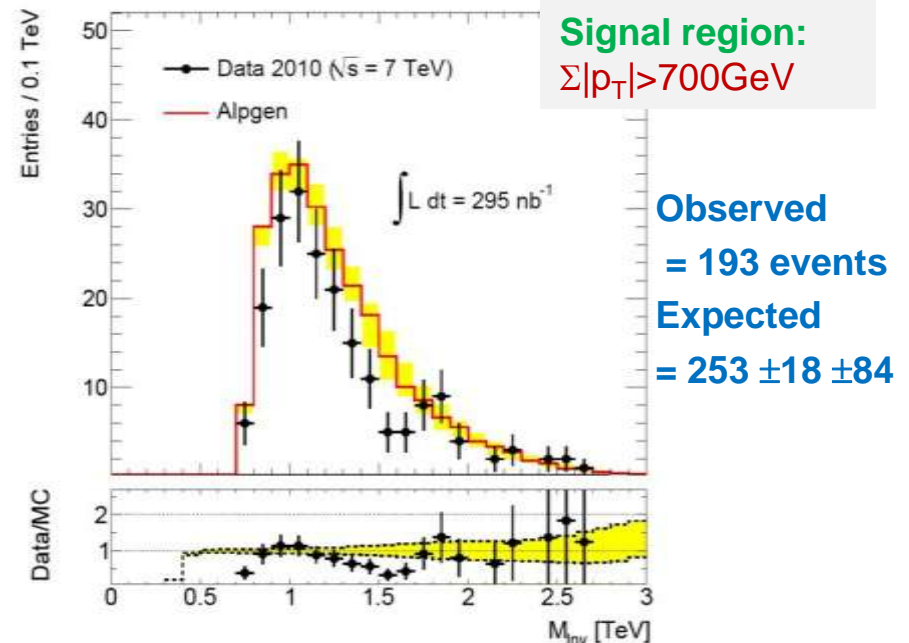
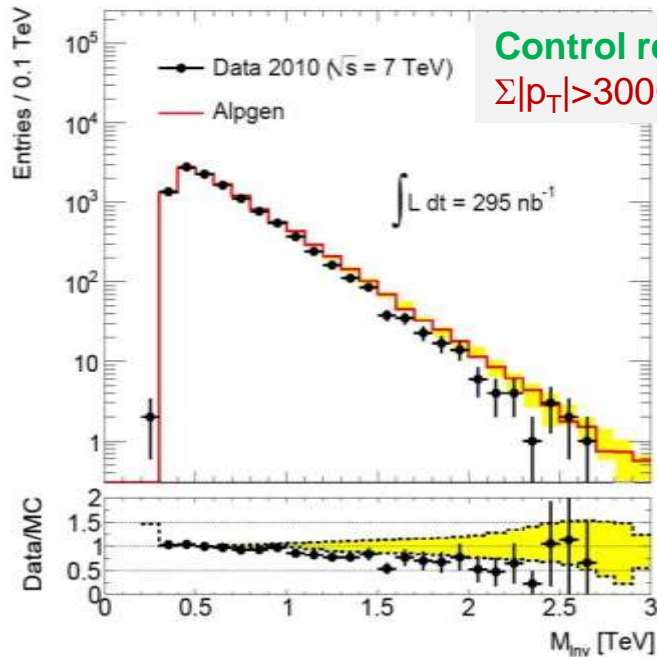

- **95%CL upper limit of 0.34 nb** for cross section  $\times$  acceptance for final states with at least three particles and an invariant mass above **800 GeV** and  $\Sigma|p_T| > 700 \text{ GeV}$
- **95%CL upper limit of 0.6 nb** for cross section ( acceptance  $\sim 55\%$  for the model used )
- The result is of interest for models of low-scale gravity and weakly-coupled string theory (cross section can be as high as  $O(100 \text{ nb})$  (Black Max) )
- ***This is the first search of this type***

Physics results from first data since April 2010 **TASK H-1 (Wu)**

## W, Z and W'

***S. L. Wu, Assistant scientist Flores, Postdocs Ma, Sarangi,  
Grad. Students Carrillo, A. Castaneda, E. Castaneda, Pedraza***

11. Observation of  $W \rightarrow l\nu$  and  $Z \rightarrow ll$  production in proton-proton collisions at  $\sqrt{s}=7$  TeV with the ATLAS detector
12. Measurement of  $W \rightarrow l\nu$  production cross section and observation of  $Z \rightarrow ll$  production in proton-proton collisions at  $\sqrt{s}=7$  TeV with the ATLAS Detector
13. Measurement of the  $Z \rightarrow ll$  production cross section in proton-proton collisions at  $\sqrt{s}=7$  TeV with ATLAS detector
14. Measurement of Z + Jets Cross Section at  $1 \text{ pb}^{-1}$
15. Search for high-mass states with lepton plus missing transverse energy using the ATLAS Detector at  $\sqrt{s}=7$  TeV

**Conf note 11 : Observation of  $W \rightarrow l\nu$  and  $Z \rightarrow ll$  production in proton-proton collisions at  $\sqrt{s}=7$  TeV with the ATLAS detector (PLHC 2010, DESY)**

$$m_T = \sqrt{2p_T^\ell p_T^\nu (1 - \cos(\phi^\ell - \phi^\nu))}$$

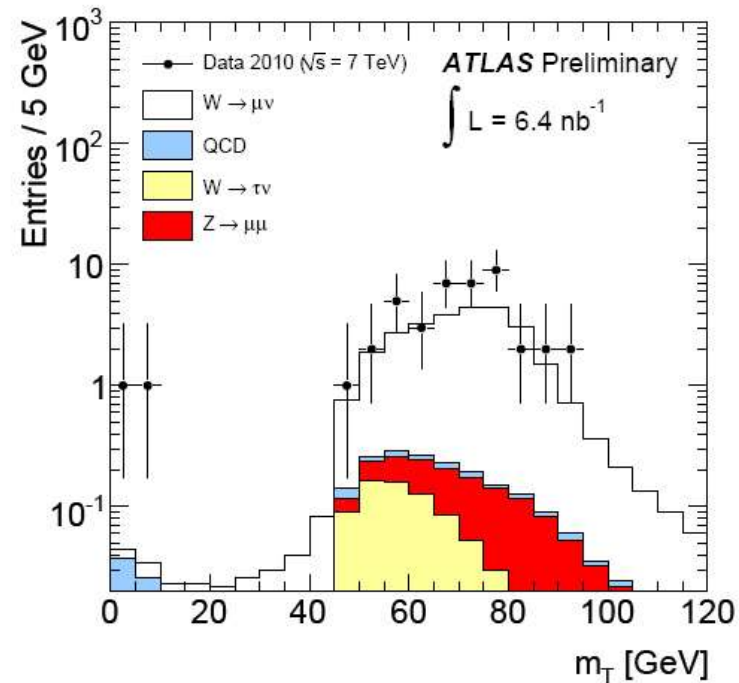
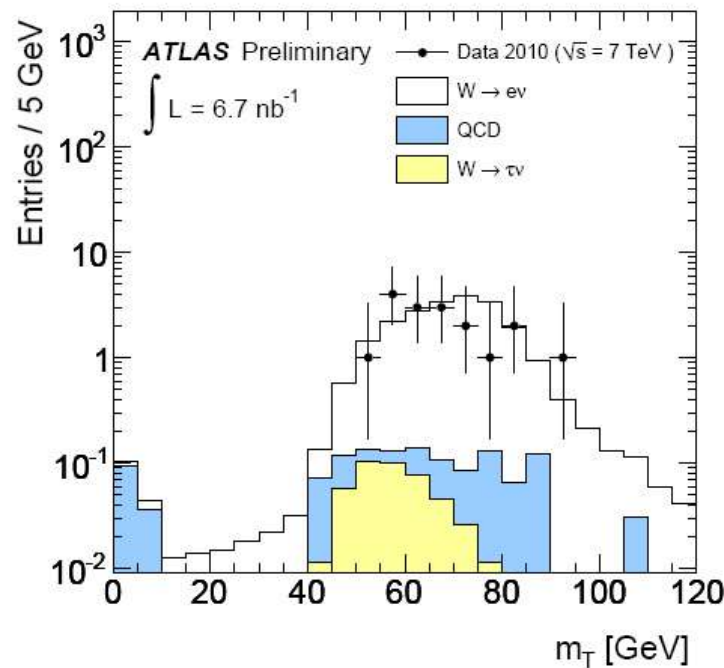

**First observation of W and Z in ATLAS ( $6.7 \text{ nb}^{-1}$ )**

- $W \rightarrow l\nu$  : 57 events
- $Z \rightarrow ll$  : 3 events

**Conf note 12 : Measurement of  $W \rightarrow l\nu$  production cross section and observation of  $Z \rightarrow ll$  production in proton-proton collisions at  $\sqrt{s}=7$  TeV (ICHEP 2010. Paris)**

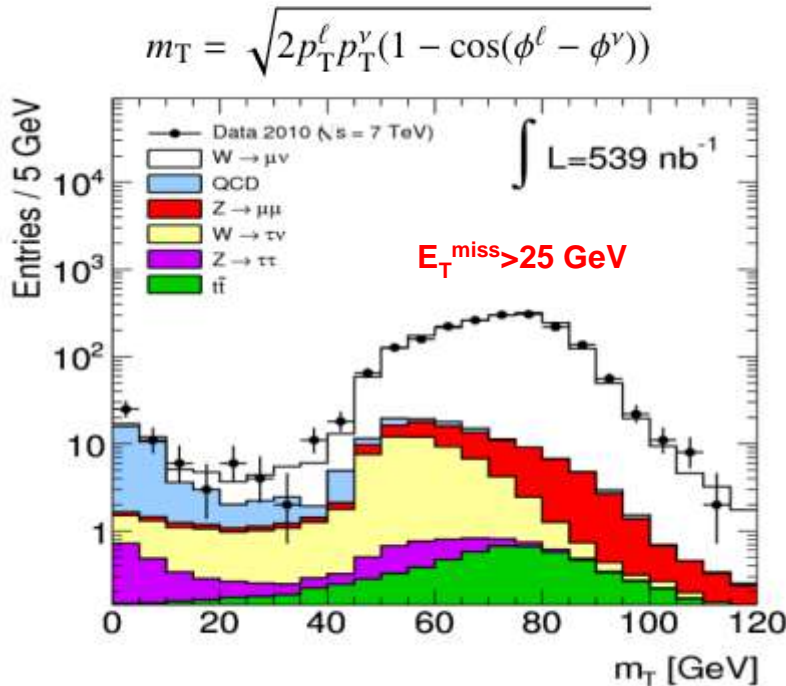

**Asymmetry (ICHEP results 17 nb<sup>-1</sup>)**

$$A = \frac{\sigma(W \rightarrow \ell^+ \nu) - \sigma(W \rightarrow \ell^- \nu)}{\sigma(W \rightarrow \ell^+ \nu) + \sigma(W \rightarrow \ell^- \nu)}$$

- $A(W \rightarrow e\nu) = 0.21 \pm 0.18 \pm 0.01(\text{syst})$
- $A(W \rightarrow \mu\nu) = 0.33 \pm 0.12 \pm 0.01(\text{syst})$   
(NNLO prediction:  $A=0.2$ )

$$P = uud$$

$$W^+ = u\bar{d}$$

$$W^- = d\bar{u}$$

**ICHEP results (17 nb<sup>-1</sup>)**

$$\sigma(W \rightarrow l\nu) = 9.3 \pm 0.9(\text{stat}) \pm 0.6(\text{syst}) \pm 1.0(\text{lumi}) \text{ nb}$$

$$\sigma(W \rightarrow e\nu) = 8.5 \pm 1.3(\text{stat}) \pm 0.7(\text{syst}) \pm 0.9(\text{lumi}) \text{ nb}$$

$$\sigma(W \rightarrow \mu\nu) = 10.3 \pm 1.3(\text{stat}) \pm 0.8(\text{syst}) \pm 1.1(\text{lumi}) \text{ nb}$$

NNLO: **10.46** nb

119 events:  
47  $W \rightarrow e\nu$   
72  $W \rightarrow \mu\nu$

**Conf note 13 : Measurement of the  $Z \rightarrow ll$  production cross section in proton-proton collisions at  $\sqrt{s} = 7$  TeV (ICHEP 2010, Paris)**

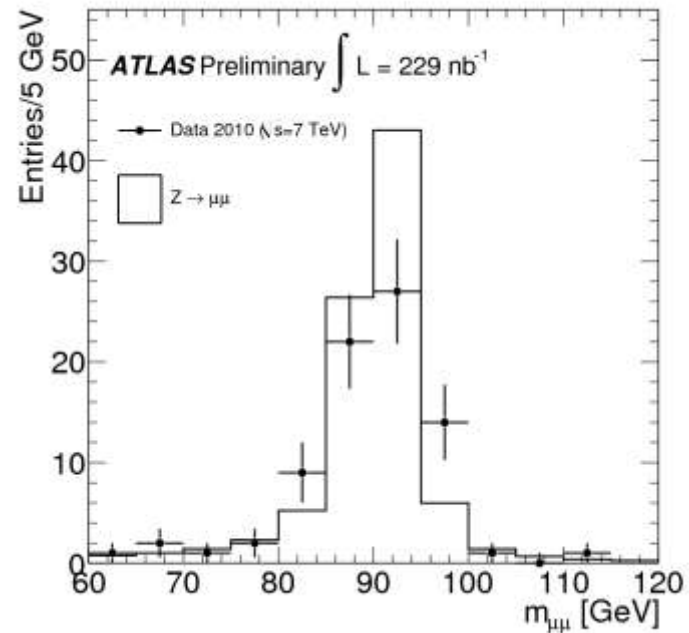
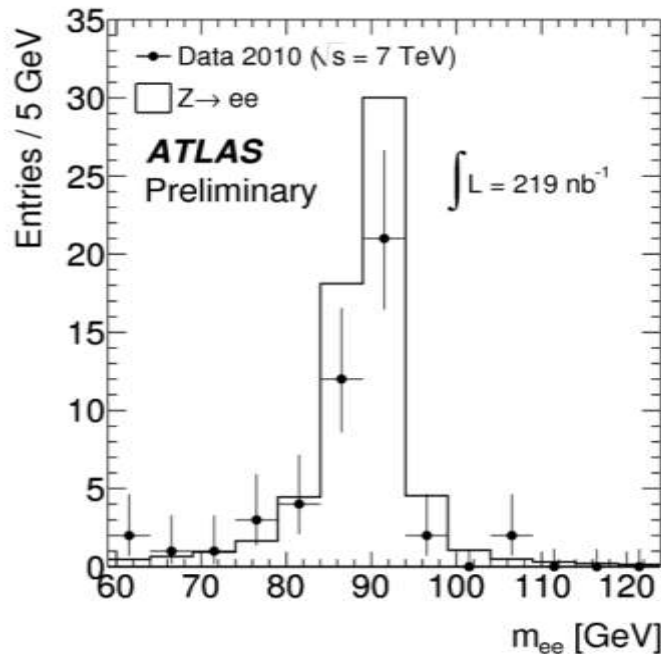

**ICHEP results  $225 \text{ nb}^{-1}$**

$$\sigma(Z \rightarrow ll) = 0.83 \pm 0.07(\text{stat}) \pm 0.06(\text{syst}) \pm 0.09(\text{lumi}) \text{ nb}$$

NNLO: **0.99** nb per family for  $m_{ll} > 60 \text{ GeV}$

$\sigma(Z \rightarrow ee) = 0.72 \pm 0.11(\text{stat}) \pm 0.10(\text{syst}) \pm 0.08(\text{lumi}) \text{ nb}$

$\sigma(Z \rightarrow \mu\mu) = 0.89 \pm 0.10(\text{stat}) \pm 0.07(\text{syst}) \pm 0.10(\text{lumi}) \text{ nb}$

**125 events:**

**46  $Z \rightarrow ee$**

**79  $Z \rightarrow \mu\mu$**

Z mass is updated to  $1.22 \text{ pb}^{-1}$

424  $Z \rightarrow \mu\mu$  candidates (Staco)

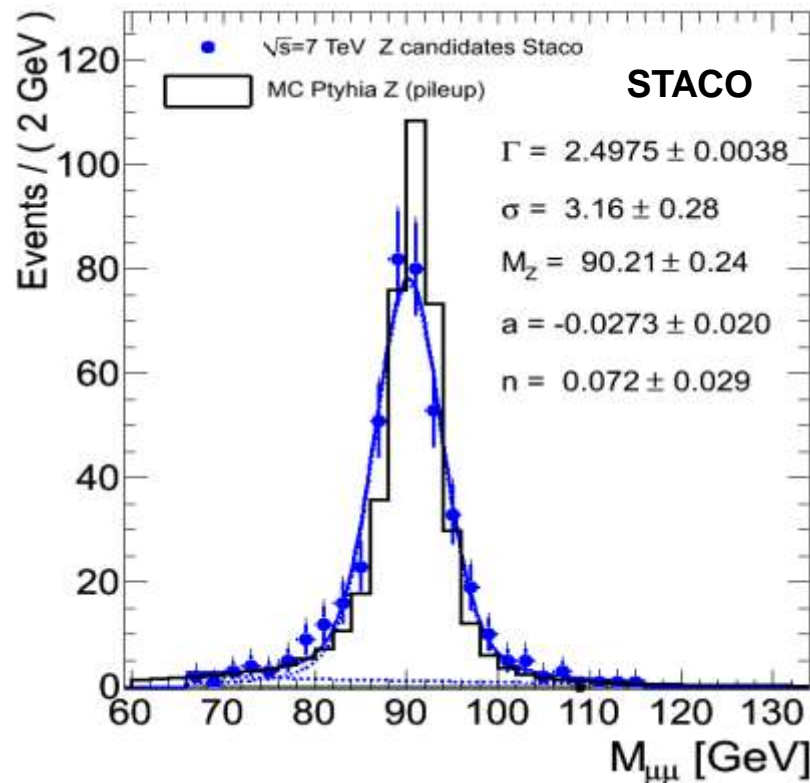
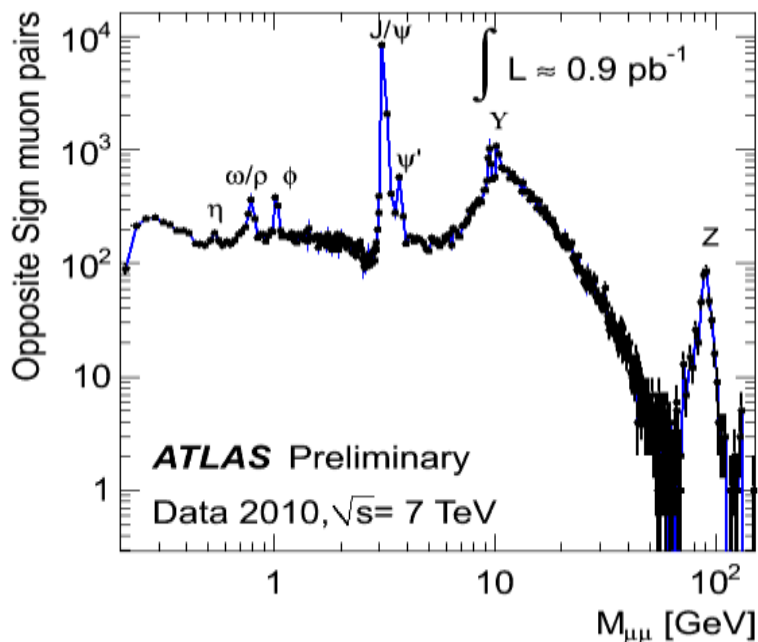

Fitting function for Z mass :  
Breit-Wigner (Z) convoluted with a Gaussian  
(Resolution) + Exponential (Low Drell-Yan)

$$\frac{1}{(x - M_Z)^2 + \frac{1}{4}\Gamma^2} \otimes \exp\left(-\frac{(x - M_Z)^2}{2\sigma^2}\right) + e^{a \cdot x}$$

$\sigma = 3.16 \pm 0.28 \text{ GeV (data)}$

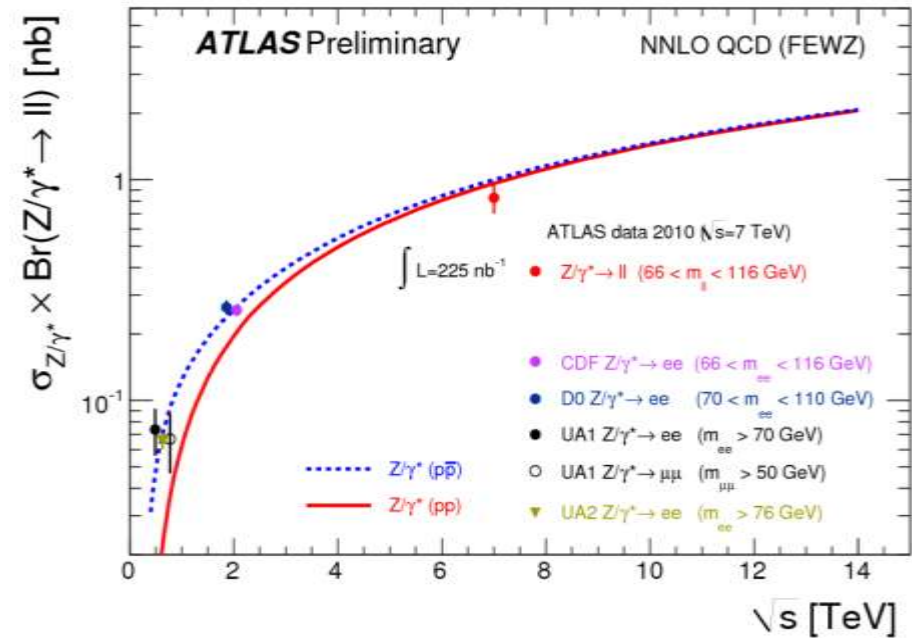
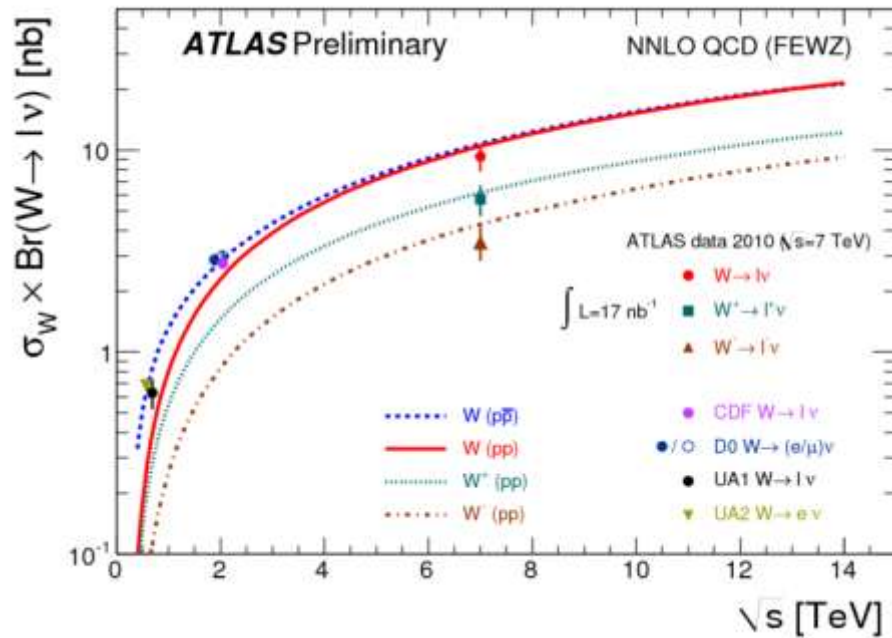

- **Good agreement with theoretical expectations, both on cross sections and asymmetry.**
- **Submission for publication is expected in September/October for  $300 \text{ nb}^{-1}$  data.**

**Conf note 14 : Measurement of Z + Jets Cross Section at  $1 \text{ pb}^{-1}$**   
(International Symposium On Multiparticle Dynamics (ISMD 2010). Sep 2010,  
Antwerp, Belgium; Figures shown in HCP 2010, Toronto)

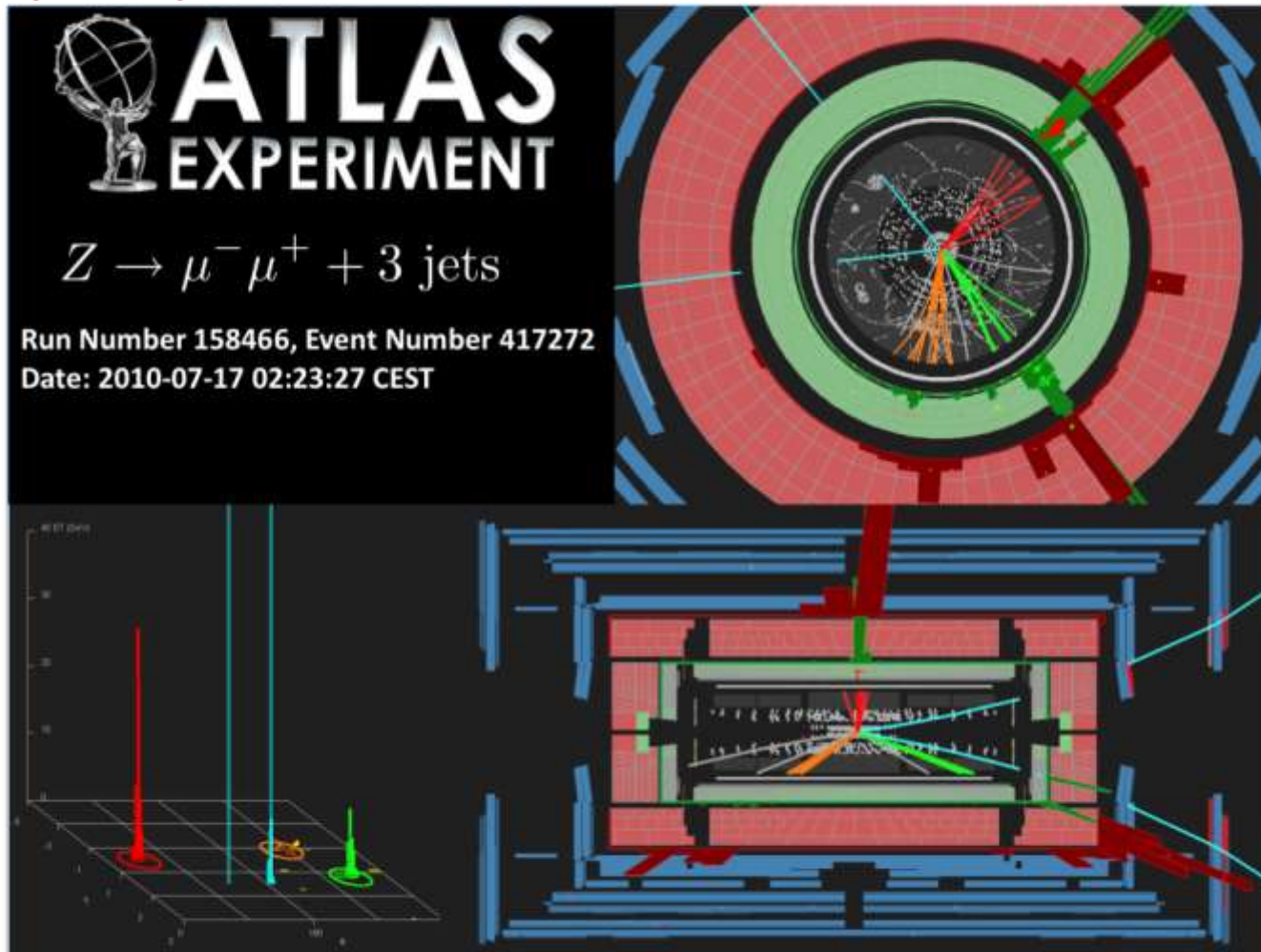

**Conf note 14 : Measurement of Z + Jets Cross Section at  $1 \text{ pb}^{-1}$**   
 (ISMD 2010, Antwerp, Belgium; Figures shown in HCP 2010, Toronto)

Measure the cross section ratio  $Z(\rightarrow l^+l^-) + N \text{ jets} / Z(\rightarrow l^+l^-)$  and compare with theoretical predictions from fixed-order NLO

**Z  $\rightarrow ee, \mu\mu$  combined**

**$0.9 \text{ pb}^{-1}$**

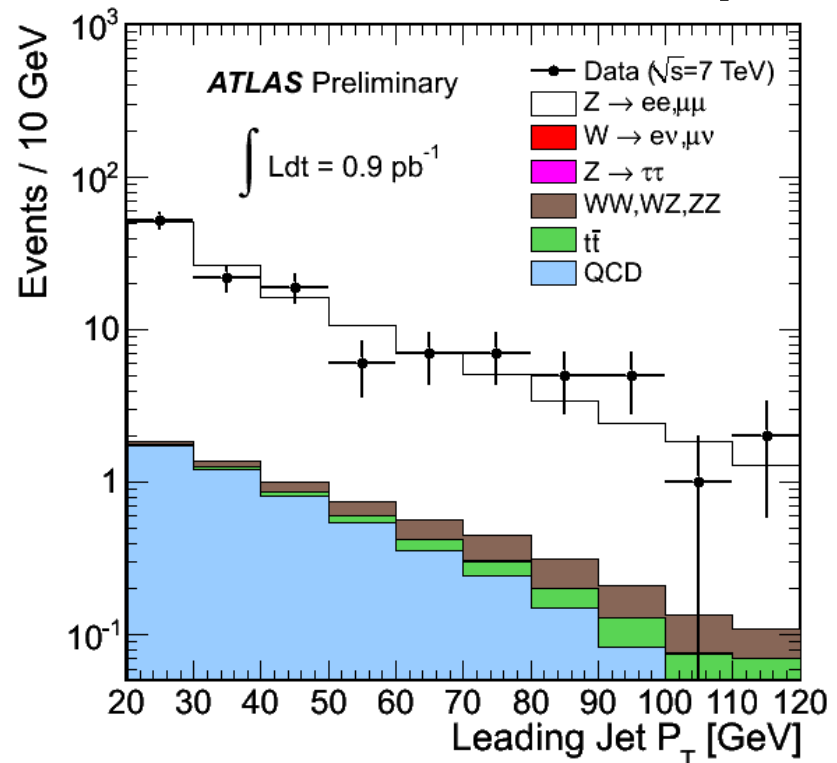
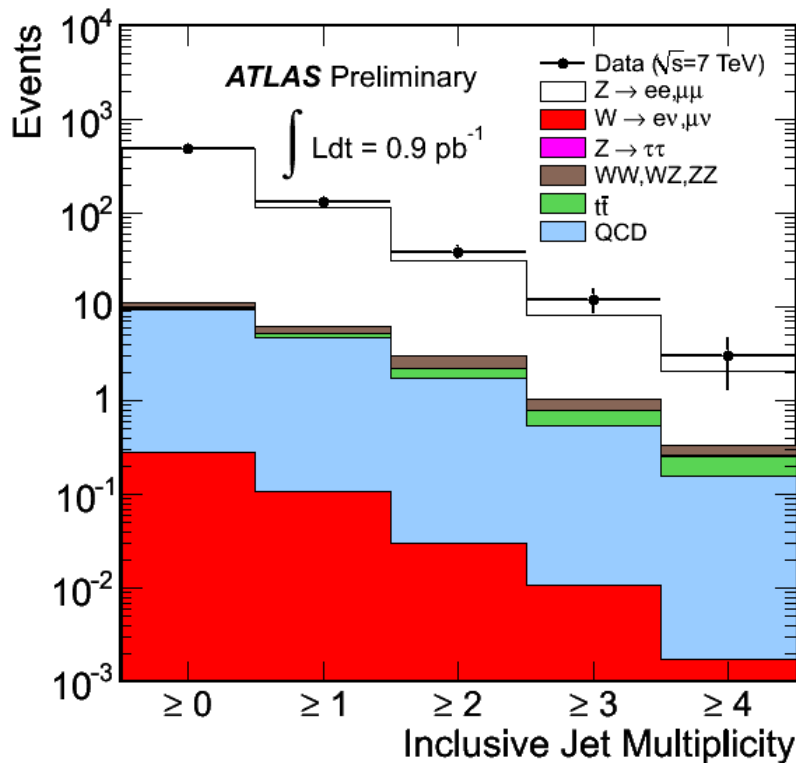

**Conf note 15 : Search for high-mass states with lepton plus missing transverse energy using the ATLAS Detector at  $\sqrt{s}=7$  TeV (HCP 2010, Toronto)**

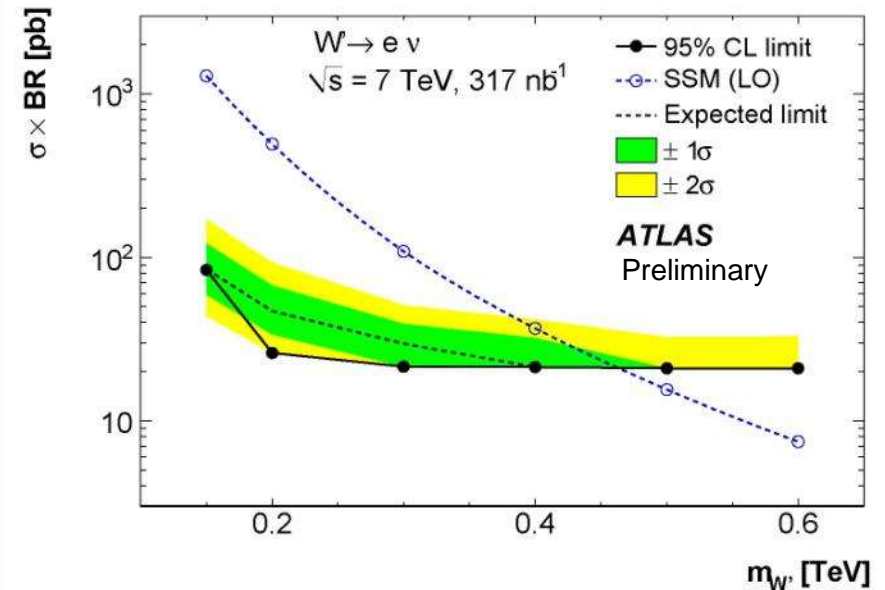
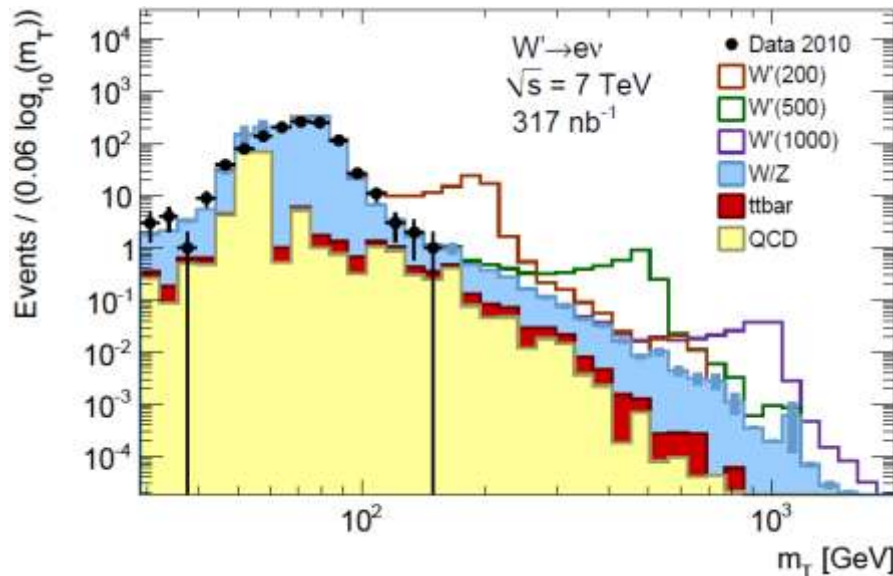

- For Sequential Standard Model, we obtain limits on **cross section  $\times$  BR** as a function of  $m_{W'}$
- 95% C.L. exclusion:  **$m_{W'} > 460$  GeV**
  - Tevatron limit:  **$m_{W'} > 1$  TeV**
- ATLAS limit will be competitive with Tevatron with  $\sim 5$  pb $^{-1}$

Physics results from first data since April 2010 **TASK H-1 (Wu)**

# Physics with photons

**S. L. Wu, Postdocs Fang, Ma, Grad. Students Wang**

16. Evidence for prompt photon production in pp collisions at  $\sqrt{s}=7$  TeV
17. Search for a two photon + ETmiss final state in  $\sqrt{s}=7$  TeV pp collisions at the LHC using the ATLAS detector in the context of the One Universal Extra Dimension model with gravity mediated decays

**Conf note 16 : Evidence for prompt photon production in pp collisions at  $\sqrt{s}=7$  TeV (ICHEP 2010, Paris)**

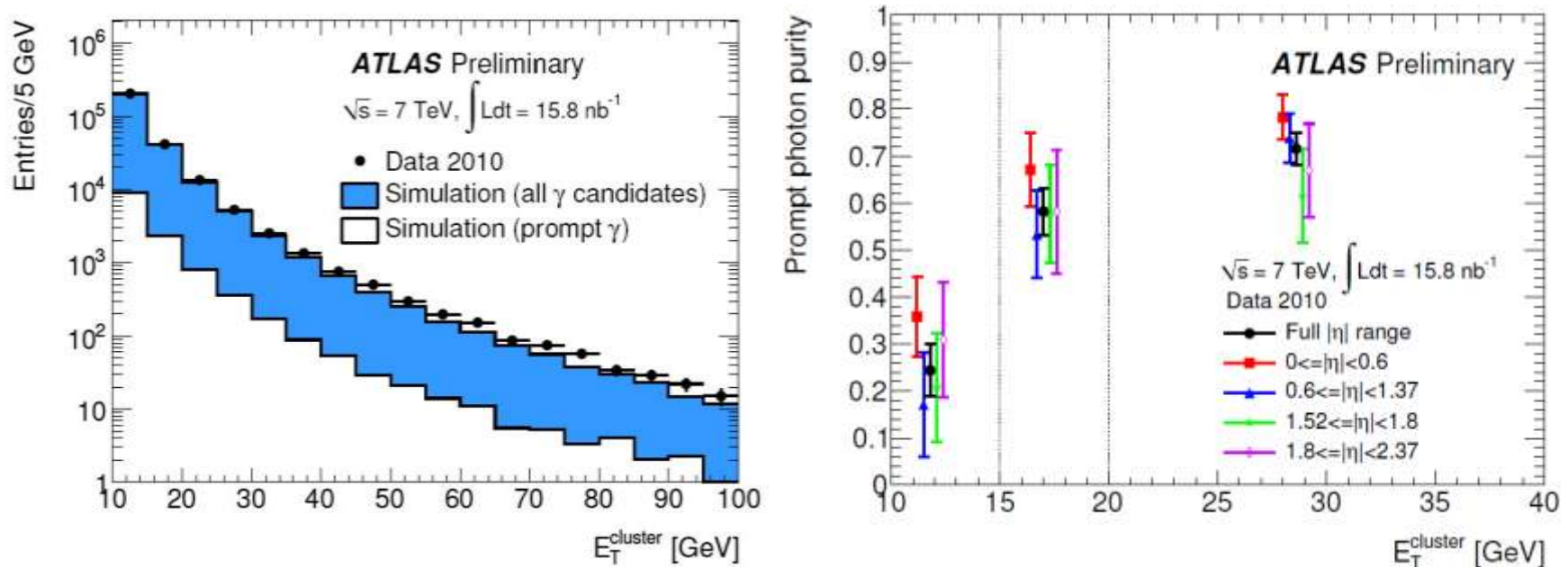

- Measurement of inclusive prompt-photon production would give a test of perturbative QCD with the potential to constrain PDF
- Statistically significant signal of prompt photons from 16 nb $^{-1}$ 
  - Yield:  $N = (618 \pm 72)$
  - Purity :  $P = (72 \pm 7) \%$  (Use shower shapes and isolation variables)

**Conf note 17 : Search for a two photon + ETmiss final state in  $\sqrt{s}=7$  TeV in the context of the One Universal Extra Dimension model with gravity mediated decays** (Fourth ATLAS Physics Workshop of the Americas. August , 2010, University of Texas, Arlington, TX) (ISMD 2010. Sep 2010, Antwerp, Belgium)

Cheng, Matchev, and Schmaltz [Phys. Rev. D66, 056006 (2002)]

**Motivation : Look for signature of two photons and missing energy**

**Inspired by : Theory of UED**

In one-dimensional UED, each SM particle has  $n = 1, 2, 3, \dots$  Kaluza-Klein (KK) excitations of squared mass

$$m_n^2 = m_{SM}^2 + n^2 / R^2$$

with the  $n = 0$  state corresponding to the SM particle. Due to momentum conservation in the extra dimension, KK particles are not produced singly.

If the (4+1)-dimensional UED space is embedded into a larger space of (4+N) dimensions into which only gravity propagates, KK particles may decay directly to photon by emitting a graviton.

**Signature : Two photons and two gravitons  $\rightarrow$  two photons + missing energy**

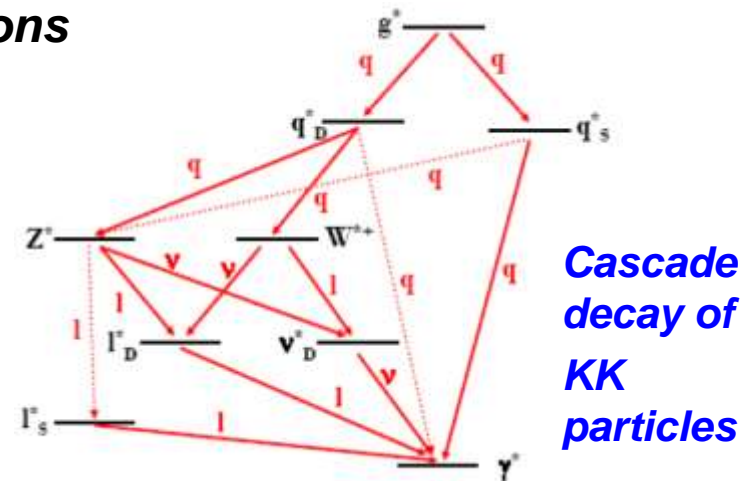

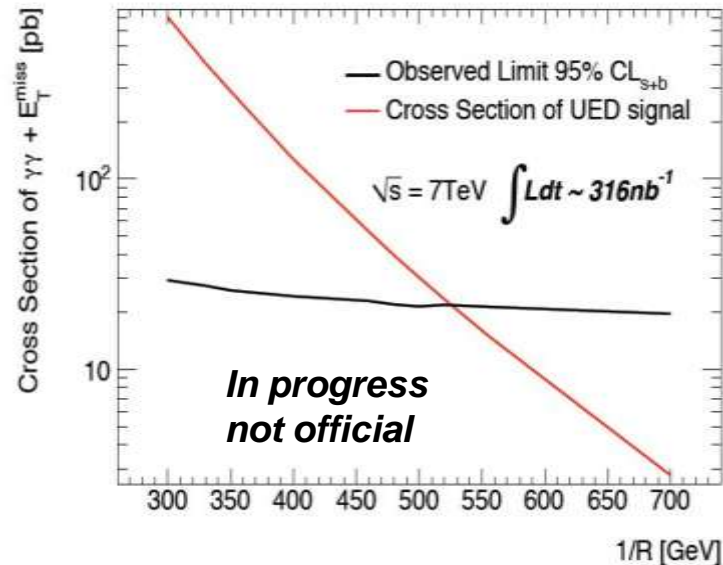
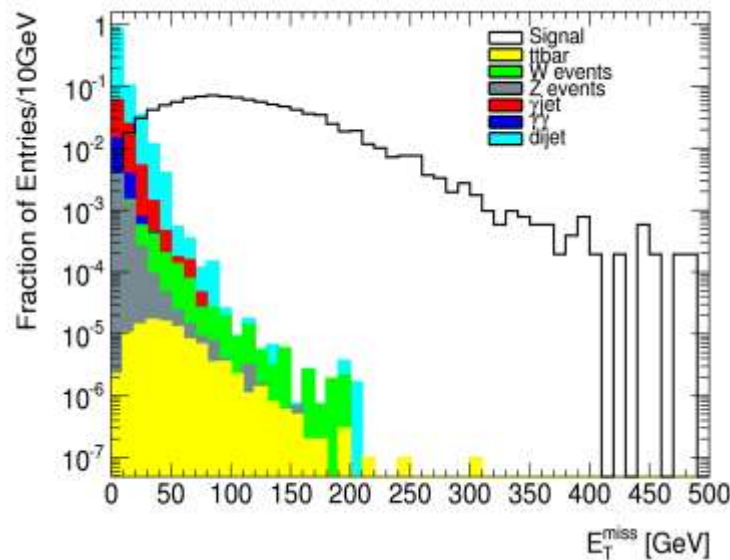

ATLAS  
workshop in  
Arlington, TX

Plan to  
submit for  
publication  
in Sept./Oct.

- We use cross section and branch ratio given by “New signal for universal extra dimensions”  
[C. Macesanu](#), [C.D. McMullen](#), [S. Nandi](#), Phys. Lett. B 546 (2002), 253
- **The gravity mediated UED model with  $N=6$  and  $\Delta R=20$  is excluded for a curvature  $1/R=520$  GeV at 95% C.L. with  $316\text{nb}^{-1}$  (In progress, not official)**
- Excluded by D0 for a curvature  $1/R \leq 477$  GeV at 95% C.L. ( $6.3\text{fb}^{-1}$ ) (arXiv : 1008.2113v1 [hep-ex] 12 Aug 2010)
- R is the radius of the Universal Extra Dimension

Physics results from first data since April 2010 **TASK H-1 (Wu)**

# SUSY

***S. L. Wu, Postdocs Chen, Poveda, Sarangi,  
Grad. Student A. Castaneda***

18. **Early supersymmetry searches with jets, missing transverse momentum and one or more leptons with the ATLAS Detector**

**Conf note 18 : Early supersymmetry searches with jets, missing transverse momentum and one or more leptons with the ATLAS Detector (ICHEP 2010)**

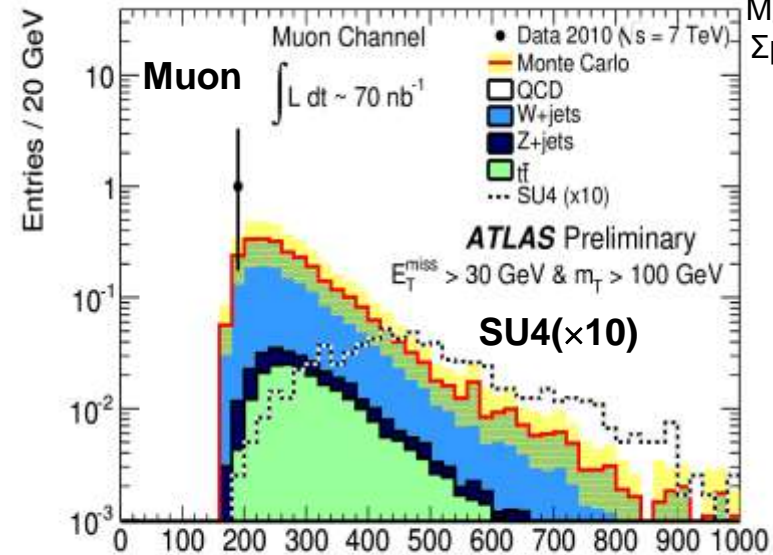
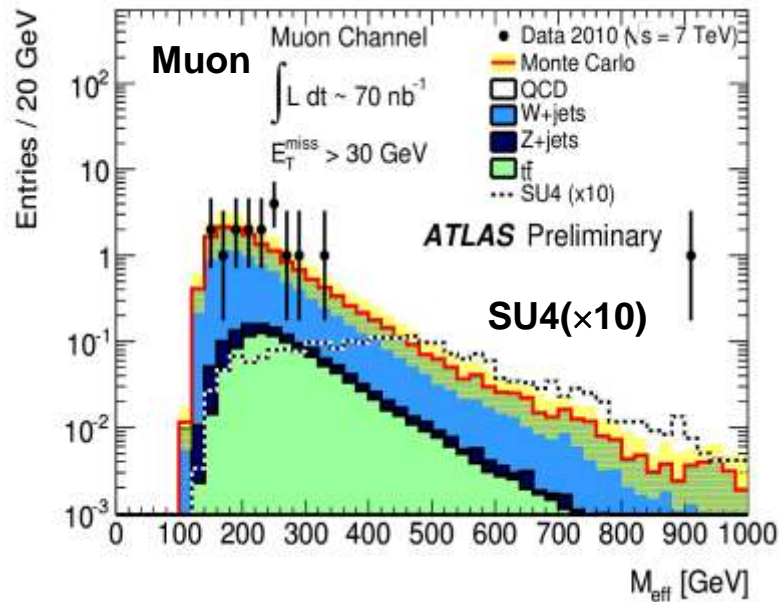

$$M_{\text{eff}} = p_T(\text{lepton}) + \Sigma p_T(\text{jets}) + E_T^{\text{miss}}$$

**ICHEP results**

- Analysis with very loose cuts: 1 isolated lepton, 2 jets with 30 GeV,  $E_T^{\text{miss}} > 30$  GeV and  $M_T > 100$  GeV
- With  $70 \text{ nb}^{-1}$ , some events passing the cuts are observed with good agreement with Monte Carlo
- Typical low-mass SUSY point included in the plots as a reference (“SU4”: point with squark and gluino masses around 410 GeV)

Electron  $M_{\text{eff}}$  [GeV] SU4(x10)

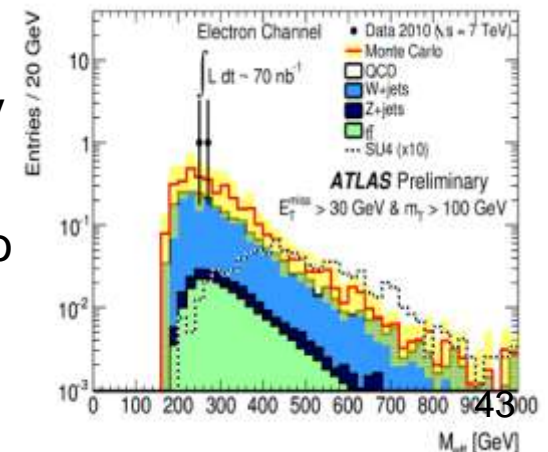

Updated to 0.8 pb<sup>-1</sup> (In progress)

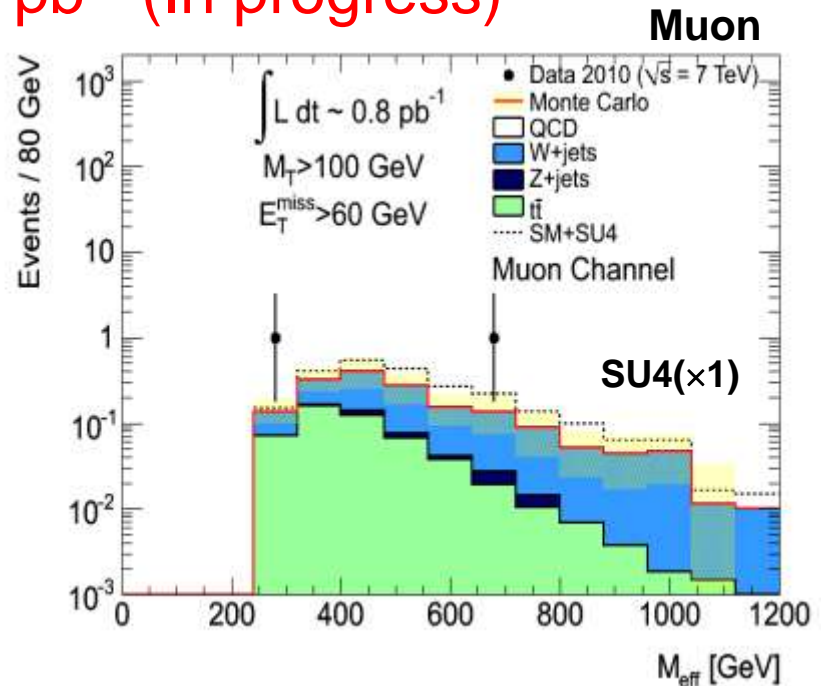
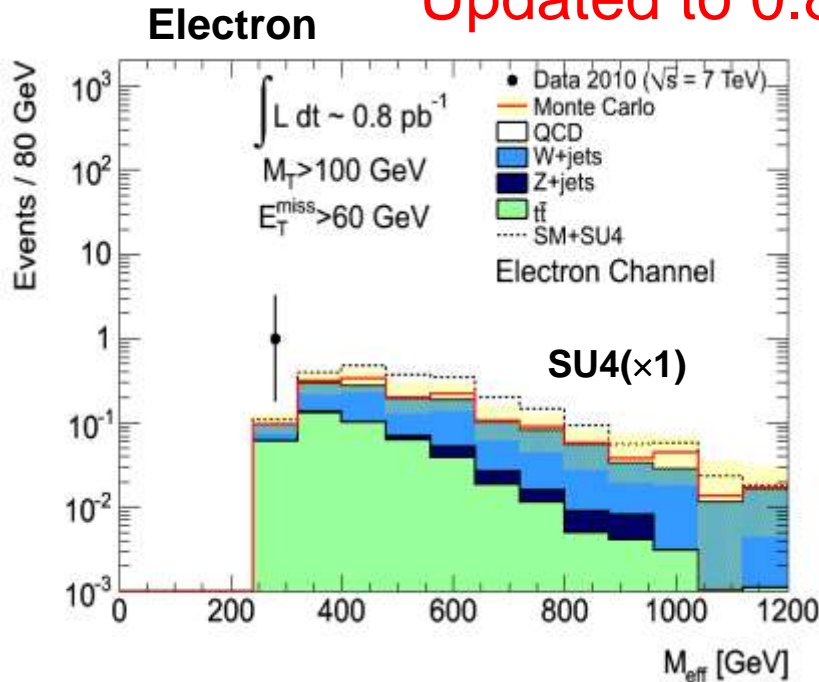

### Cuts

- 3 jets (pT leading jet more than 60 GeV, pT other jets more than 30 GeV)
- $E_T^{\text{miss}} > 60 \text{ GeV}$  and  $M_T > 100 \text{ GeV}$

### The number of events:

- Electron channel: data = 1 ; (Background MC = 1.5 +/- 0.5; SU4 : 0.78)
- Muon channel: data = 2; (Background MC: 1.6 +/- 0.6; SU4: 0.72)

Physics results from first data since April 2010 **TASK H-1 (Wu)**

# Higgs

***S. L. Wu, Assistant scientists Flores, Postdocs Fang, Quayle,  
Grad. Students Asfandiyarov, Carrillo, Sabbatini, Wang***

19. Measurement of Background from W+jets to the  $H \rightarrow WW^* \rightarrow l\nu l\nu$  Search at  $\sqrt{s}=7$  TeV
20. Test of data driven ZZ and Z+jets background estimation methods for the Higgs boson search in the 4-lepton final state

**Conf note 19 : Measurement of the Background from W+jets to the  $H \rightarrow WW^* \rightarrow l\nu l\nu$  Search at  $\sqrt{s}=7$  TeV (HCP 2010, Toronto)**

$H \rightarrow WW \rightarrow l\nu l\nu$

- Background : W + jets  
(jet gives fake lepton)  
Need to measure the fake rate of e or  $\mu$   
from jets in data
- From  $311 \text{ nb}^{-1}$  data, events with one good lepton and one fake lepton together with large Missing ET.  
9 events are observed (W+jets candidates).
- In this note, methods are proposed to estimate from data the lepton fake rates.

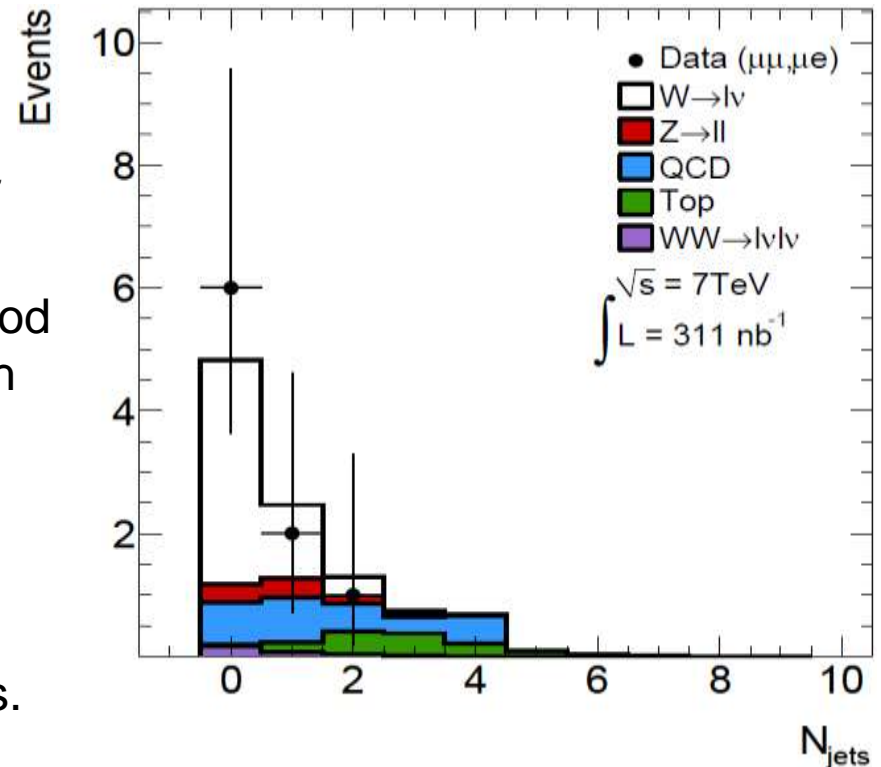

Conf note 19 : **Measurement of the Background from  $W$ +jets to the  $H \rightarrow WW^* \rightarrow l\nu l\nu$  Search at  $\sqrt{s}=7$  TeV (HCP 2010, Toronto)**

Example : Use  $\gamma$  + jet control sample,

Back to back



Jet  $\rightarrow$  e

Work of Postdoc Fang

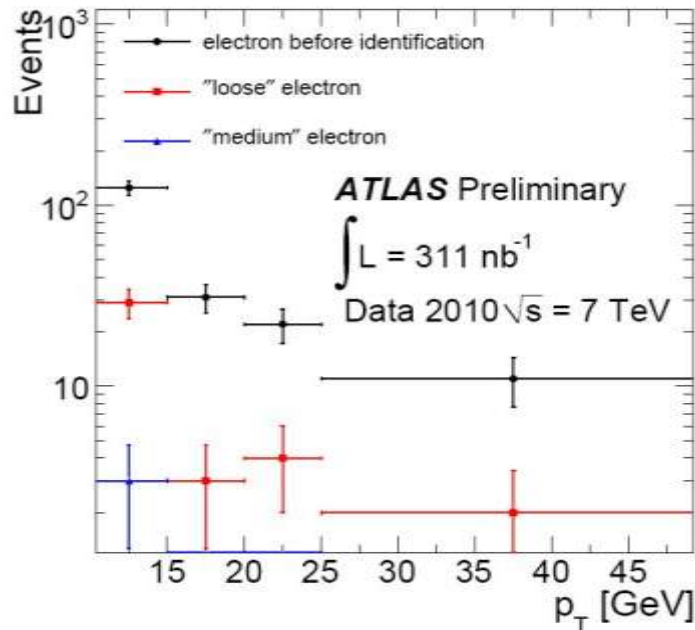

Fake rate from loose to medium is  $0.11 \pm 0.05$ .

effect of pileup on jet veto

Work of Student Ruslan Asfandiyarov

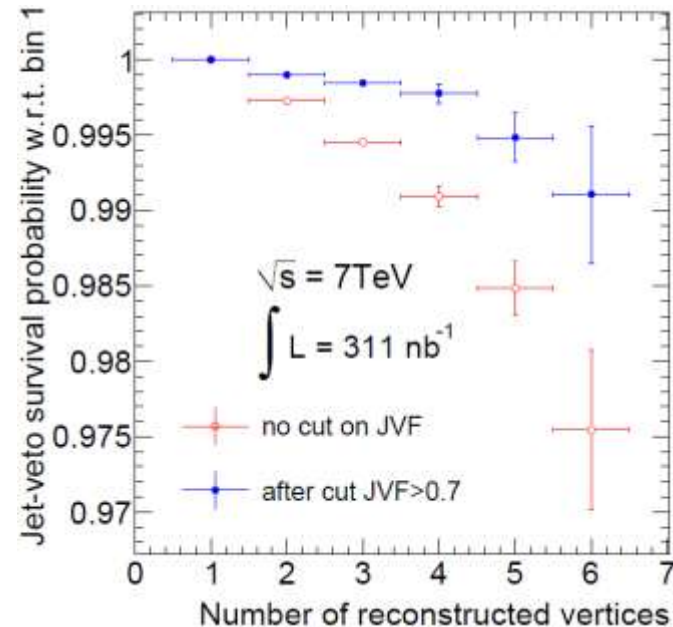

- $JVF$  is the sum  $p_T$  of all matched-tracks from a given vertex divided by the total jet-matched track  $p_T$ :

**Conf note 20 : Test of data driven ZZ and Z+jets background estimation methods for the Higgs boson search in the 4-lepton final state** (International Symposium On Multiparticle Dynamics (ISMD 2010). Sep 2010, Antwerp, Belgium)

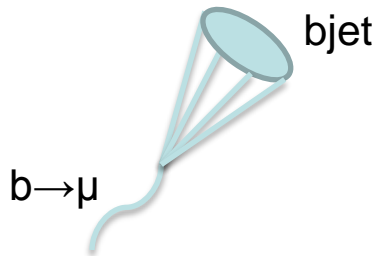

In  $H \rightarrow ZZ$

- Irreducible background : ZZ
- Reducible background : Z + jets which is dominated by Zbb ( $b \rightarrow \mu$ )
- Use data driven method to estimate Zbb

From 331 nb<sup>-1</sup> data

- Obtain events with 1 good quality b-tagging jet and 1 non-isolated lepton (A). Also obtain events with 1 good quality b-tagging jet and 1 isolated lepton (B). The b jet and lepton should be back to back in the transverse plane.
- The ratio of B over A will be used to estimate the Zbb background.

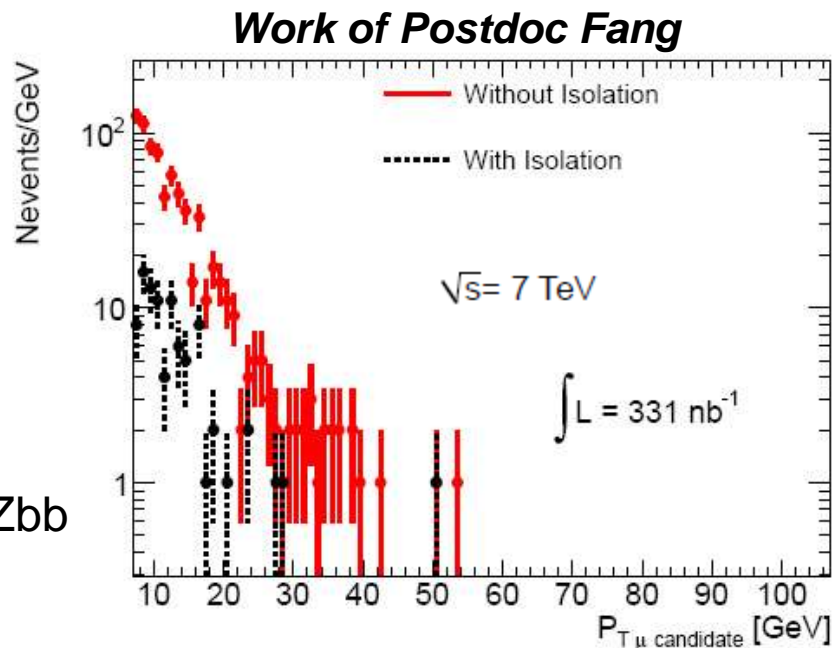

# Public Notes Contributed to Conferences(Monte Carlo) **Task H-1 (Wu)**

## **SUSY**

**1. Searching for Supersymmetry with two same-sign leptons, multi-jets plus missing transverse energy in ATLAS at  $\sqrt{s}=10$  TeV,**

ATL-PHYS-PUB-2009-085, Aug 2009

**2. Prospects for Supersymmetry discovery based on inclusive searches at a 7 TeV centre-of-mass energy with the ATLAS detector**

ATL-PHYS-PUB-2010-010, Jul 2010

## **$W'$ , $Z'$**

**3. ATLAS sensitivity prospects to  $W'$  and  $Z'$  in the decay channels  $W' \rightarrow l\nu$  and  $Z' \rightarrow l+l-$  at  $\sqrt{s}=7$  TeV**

ATL-PHYS-PUB-2010-007, Jul 2010

# Public Notes Contributed to Conferences(Monte Carlo) **Task H-1 (Wu)**

## **Higgs**

**4. Prospects for Higgs Boson Searches using the  $H \rightarrow WW^* \rightarrow l\nu l\nu$  Decay Mode with the ATLAS Detector for 10 TeV**

ATL-PHYS-PUB-2010-005, Jun 2010

**5. ATLAS Sensitivity Prospects for Higgs Boson Production at the LHC Running at 7 TeV**

ATL-PHYS-PUB-2010-009, Jul 2010

## **Publication (Detector performance)**

**6. Combined performance studies of the ATLAS detector using cosmic-ray muons, To be submitted to: Eur. Phys. J. C**

# Publication plan for physics results involved by *Task H-1 (Wu)*

**Confidential**

<b><i>Topics</i></b>	<b><i>Expected dates of submission</i></b>
1. Dijet resonance ( $q^*$ )	Aug. 13, 2010
2. W, Z cross sections and $W^+/W^-$ asymmetry	September, 2010
3. Inclusive jet cross section	September, 2010
4. Multijet cross section	October, 2010
5. Z + jets cross section	October, 2010
6. UED – diphotons + $E_T^{\text{miss}}$	October, 2010
7. $W'$ limit	October, 2010
8. New physics from dijet angular distribution	November, 2010
9. SUSY – $E_T^{\text{miss}}$ signature	November, 2010
10. New physics in multi-body final states at high invariant mass	November, 2010

# Manpower and University Contribution for Task H-1 (Wu)

- ***A conscious effort***

We have no one beyond 7 years of PhD both in our DOE-based supported program and our University funded program (except Sau Lan Wu)

- ***Since the split with Profs. Pan and Mellado in March, 2010***

Sau Lan Wu has worked closely with our present team of graduate students and research associates

(Postdoc Xin Chen will move from Task H-1 to Task H-2).

### ***DOE BASED PROGRAM SUPPORTED PERSONNEL (FY11 REQUEST)***

- ***One Assistant Scientist*** – Luis Flores
- ***One Research Associate*** – William Quayle
- ***Six Graduate Students*** – Yang Heng, Haoshuang Ji, Luca Sabbatini, Haichen Wang, Suli Yang, Fangzhou Zhang.
- ***One third FTE Computing Software Engineer*** – Neng Xu
- ***Summer salary*** – Sau Lan Wu

# UNIVERSITY SUPPORT FOR SAU LAN WU

*The University of Wisconsin has a long tradition in strong investment in my research, starting from former **Chancellor Donna Shalala**. It is due to our dedication to graduate education (**48 PhD's granted so far**) and our strong research record. Chancellor Donna Shalala was motivated also by the fact that I am one of the few female leaders in the male-dominated field of Experimental High Energy Physics.*

## ***Sau Lan Wu – Supported by various University Fellowships***

1. Romes Fellowship
2. Enrico Fermi Distinguished Professorship
3. Hilldale Professorship
4. Vilas Professor, which is the highest rank professorship in Wisconsin-Madison, with only twelve in the entire University.

Our program has also been strongly supported by the Vilas Foundation.

LHC is a high-profile research project; the University would like to assure Sau Lan Wu's success in this endeavor by supporting her research. This continuing commitment of support is made with the understanding of a similar continuing commitment of support for Wu's team from DOE.

- **Research Associates**  
Yaquan Fang, Ximo Poveda, Tapas Sarangi, Lianliang Ma and Haiping Peng.
- **Graduate Students**  
Ruslan Asfandiyarov, German Carrillo and Haifeng Li.
- **Graduate Students with a joint program with Mexican Universities**  
Alfredo Castaneda (*Universidad de San Luis Potosí*),  
Elizabeth Castaneda (*CINVESTAV, Mexico's Instituto Politécnico Nacional*)  
Isabel Pedraza (*Benemérita Universidad Autónoma de Puebla*).
- **Two thirds FTE Computing Software Engineer** – Neng Xu
- **Sau Lan Wu's academic salary**  
(9 months) each year is supported by her Vilas Professorship award. This allows her to be full-time on research at CERN.
- **The University support is equivalent to a one-to-one matching to the DOE grant.**

Near Term Goals for  
**Task H-1 (Wu) – FY11-13**

# Near Term Goals for *Task H-1 (Wu)*

- ***Silicon Read Out Driver***
  - Continue the maintenance of its full functionality
- ***High Level Trigger (HLT)***
  - Continue to maintain the full functionality of this critically important element for data taking
  - Postdocs and students continue to contribute to trigger tasks
  - Contribute to the High Level Trigger upgrade
- ***Atlas Tier-3 Development***
  - Continue to contribute to system structure design in collaboration with BNL, to improve data analysis capabilities in a distributed storage system
- ***Detector performance***
  - Continue to contribute in e/gamma, jets and missing transverse energy
- ***Shift and operation tasks.***
  - ATLAS requires 30% FTE per physicist

# Near Term Physics Goals for *Task H-1 (Wu)*

## (1) *JET PHYSICS*

(Sau Lan Wu, Postdocs Poveda, Peng, Grad Students Ji and Li)

- **Continue the study of high  $p_T$  jets**
  - Look for shoulders and deviations from QCD
  - Contribute to the calibration of high  $p_T$  jets using the multijet balance method
- **Continue the search for di-jet resonances – extend to multi-TeV dijet mass**
  - With  $315\text{nb}^{-1}$ , we have excluded  $400 < m_{q^*} < 1260$  GeV
  - **Submitted for publication (PRL) on Aug. 13, 2010**  
[arXiv:1008.2461v1\[hep-ex\]](https://arxiv.org/abs/1008.2461v1)

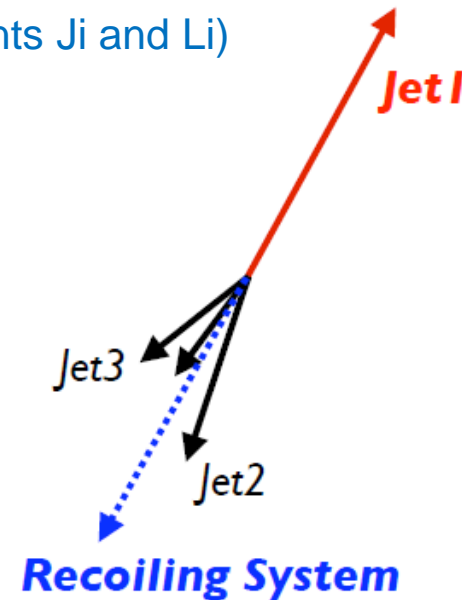

# Near Term Physics Goals for *Task H-1 (Wu)*

## **(2) BLACK HOLES AND STRING BALLS SEARCHES**

(Sau Lan Wu, Postdocs Peng and Sarangi, Grad Students Ji and A. Castaneda)

- Our analysis strategy in **search for new physics in multi-body final states at high invariant masses** will be applied to String Balls and Black Holes with additional requirements of high pT leptons to suppress QCD background.
- With  $\sim 50\text{pb}^{-1}$ , we will be able to have a 3 sigma observation of String Balls up to a mass of 3TeV
- At the **end of 2011**, with  $1\text{fb}^{-1}$ , it may be possible to observe microscopic black holes
- *Publications are expected in both 2010 and 2011*

# Near Term Physics Goals for *Task H-1 (Wu)*

## (3) High mass diphoton resonances

(Sau Lan Wu, Postdoc Fang, Grad Students Wang and Zhang)

- Model-independent search for a diphoton resonance
- New limits beyond Tevatron possible with  $\mathcal{H}(10) \text{ pb}^{-1}$ 
  - Example: Randall-Sundrum graviton (large signal cross section)
- Our group's expertise in the search for Higgs into diphotons will allow us to maintain a strong involvement in this search

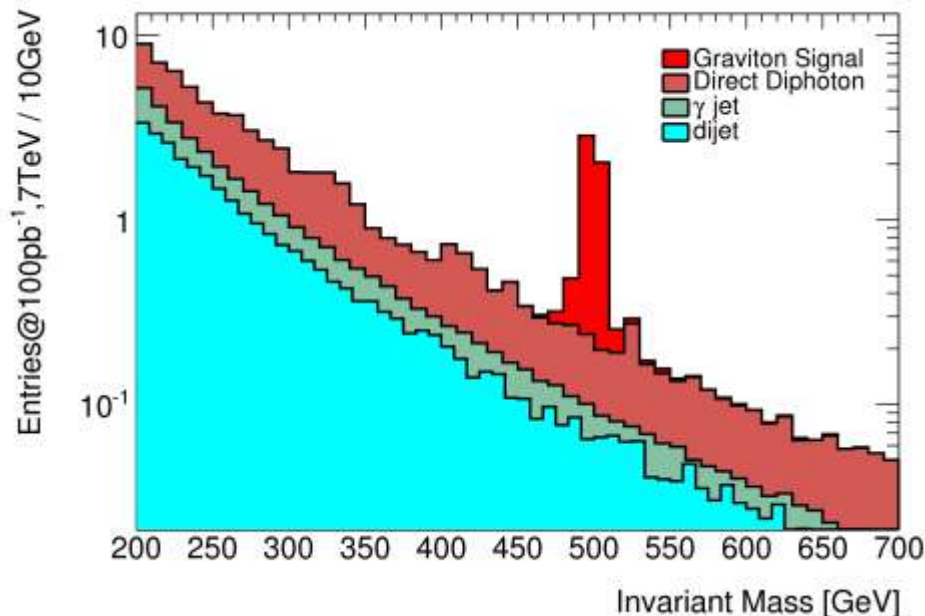
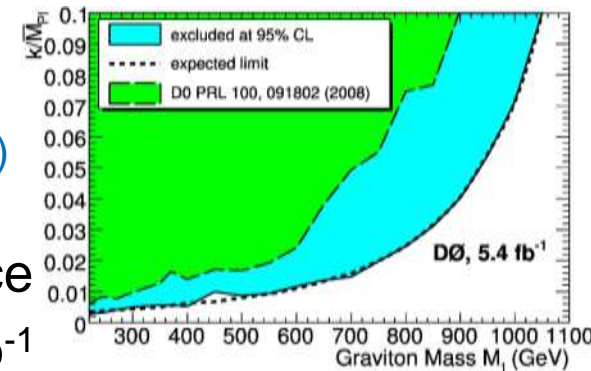

## Randall-Sundrum model

- *Gravitons are the only particles that propagate in the fifth dimension, and appear as a Kaluza-Klein series of massive excitations*
- *KK gravitons would appear as narrow resonances in the  $ee$  and  $\gamma\gamma$  invariant mass spectra*

# Near Term Physics Goals for **Task H-1 (Wu)**

## (4) **$W'$ , $Z'$**

(Sau Lan Wu, Assistant Scientist Flores, Postdoc Ma, Grad Students E. Castaneda, Pedraza and Yang)

- $W' \rightarrow \mu\nu$  and  $e\nu$ ,  $Z' \rightarrow \mu\mu$  and  $ee$
- New heavy gauge bosons may provide the first evidence of physics beyond the Standard Model at the LHC
- We will continue our leading role in these searches

## **$W'$ (SSM)**

*Tevatron exclusion:  $\sim 1\text{TeV}$*

10  $\text{pb}^{-1}$  exclusion  $\sim 1.0\text{ TeV}$   
20  $\text{pb}^{-1}$  discovery  $\sim 1.0\text{ TeV}$   
50  $\text{pb}^{-1}$  exclusion  $\sim 1.5\text{ TeV}$   
100  $\text{pb}^{-1}$  discovery  $\sim 1.5\text{ TeV}$   
1  $\text{fb}^{-1}$  discovery  $\sim 2.0\text{ TeV}$

## **$Z'$ (SSM)**

*Tevatron exclusion:  $\sim 1\text{TeV}$*

50  $\text{pb}^{-1}$  exclusion  $\sim 1.0\text{ TeV}$   
100  $\text{pb}^{-1}$  discovery  $\sim 1.0\text{ TeV}$   
300  $\text{pb}^{-1}$  exclusion  $\sim 1.5\text{ TeV}$   
1  $\text{fb}^{-1}$  discovery  $\sim 1.5\text{ TeV}$

(all exclusions quoted  
are 95% CL limits)

SSM: Sequential Standard Model

# Near Term Physics Goals for *Task H-1 (Wu)*

## (4) $W', Z'$

(Sau Lan Wu, Assistant Scientist Flores, Postdoc Ma, Grad Students E. Castaneda, Pedraza and Yang)

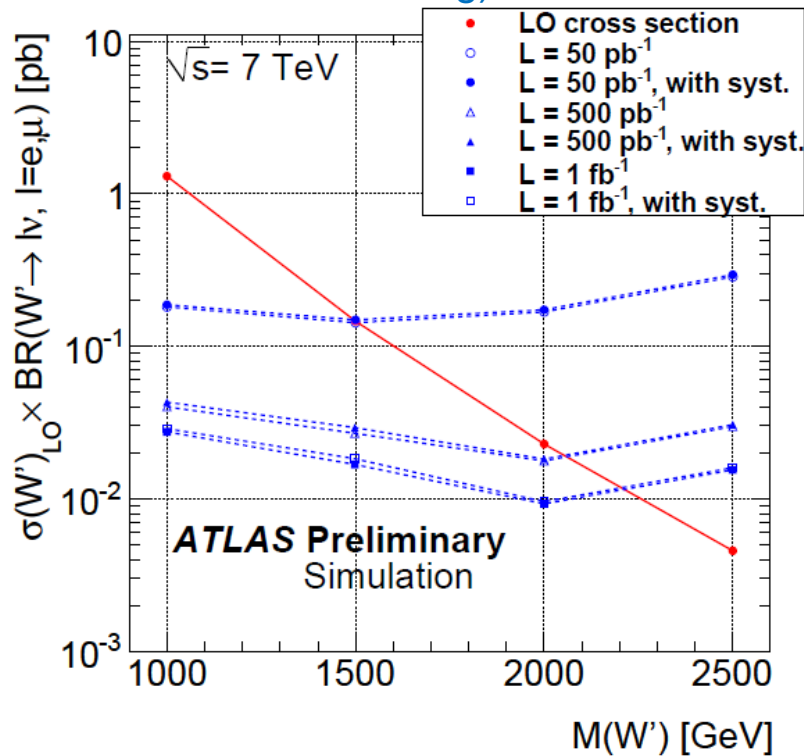

1fb<sup>-1</sup>: exclude up to ~2 TeV

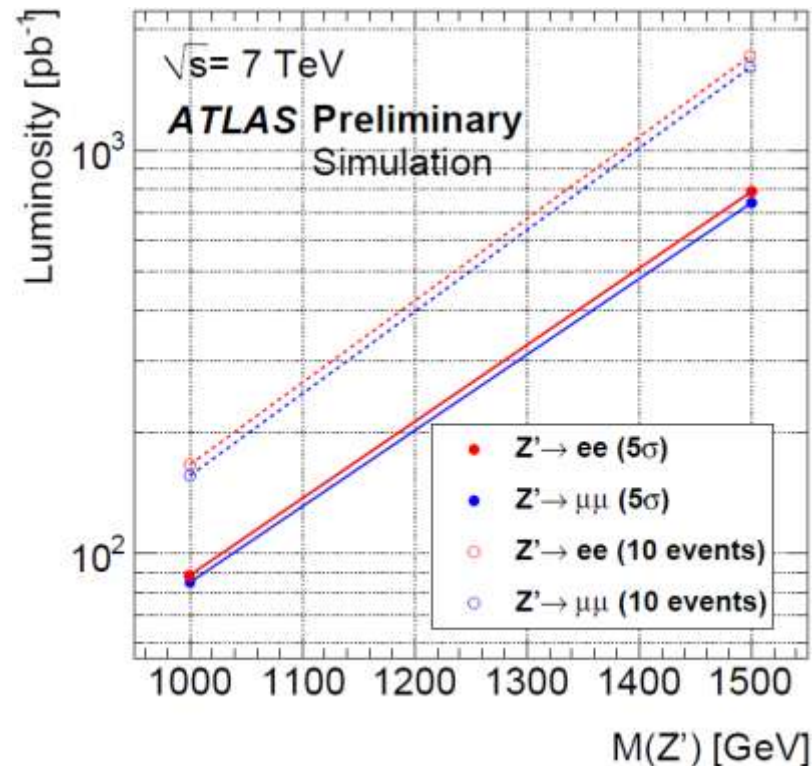

1fb<sup>-1</sup>: discovery up to ~1.5 TeV

# Near Term Physics Goals for *Task H-1 (Wu)*

## **(5) SUSY**

(Sau Lan Wu, Postdocs Poveda and Sarangi, Grad Students A.Castaneda and Heng)

- For a range of sparticle masses, discovery could be possible even with as few as **hundreds of pb<sup>-1</sup>**.
- We will continue to pursue vigorously the analysis techniques that we have developed for these searches
  - ***Inclusive studies***: 1, 2 or 3 leptons plus missing energy  
Discovery or new limits with as low as few tens of pb<sup>-1</sup>
  - ***Fit-based analysis*** for one-lepton plus missing energy  
Higher discovery and exclusion potential than cut-and-count
  - ***SUSY parameter scans***.
- **Expect to publish the physics results in both 2010 and 2011**

# Near Term Physics Goals for *Task H-1 (Wu)*

## (5) SUSY

(Sau Lan Wu, Postdocs Poveda and Sarangi, Grad Students A.Castaneda and Heng)

### • SUSY PARAMETER SCANS

$\tan\beta=10, A_0=0 \text{ GeV}, \mu>0$

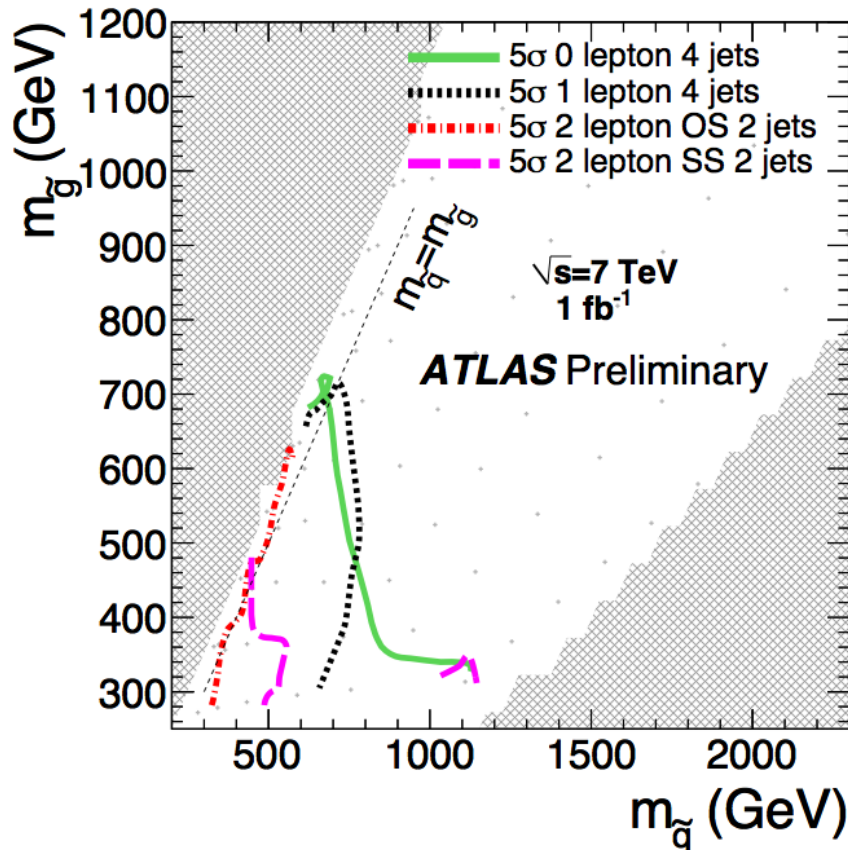

- The **minimal SuperGRAvity** (mSUGRA) model reduces the number of SUSY free parameters to **only five**,
- These five determine masses and decays of all sparticles
- Discovery reach ( $5\sigma$ ) evaluated in the mSUGRA parameter space (masses of squarks and gluinos)

**SUSY** [for  $m_{\tilde{q}} \sim m_{\tilde{g}}$ ]

*Tevatron: for  $m_q \sim m_g$ : 400GeV (95%CL)*

200 pb<sup>-1</sup> discovery up to ~480GeV

1 fb<sup>-1</sup> discovery up to ~700GeV

# Near Term Physics Goals for *Task H-1 (Wu)*

## (5) SUSY

(Sau Lan Wu, Postdocs Chen, Poveda and Sarangi, Grad Students A.Castaneda and Heng)

- Current efforts on fit-based analysis in the SUSY 1-lepton mode
- Simultaneous fit to a Control Sample and a Signal Region
- First exclusion results already obtained with  $0.8 \text{ pb}^{-1}$ . Promising prospects for higher luminosities
- ***We will perform both cut-based and fit-based analysis***

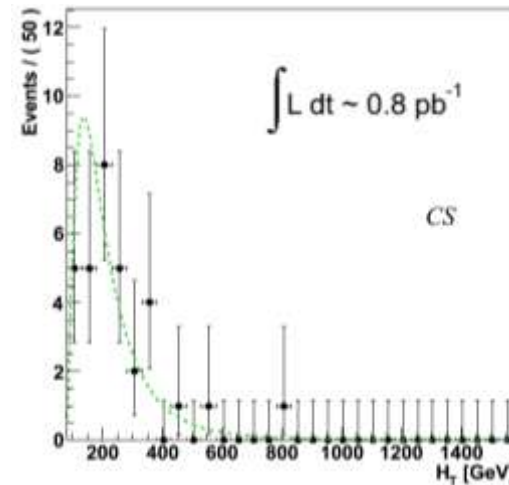

*In progress  
not official*

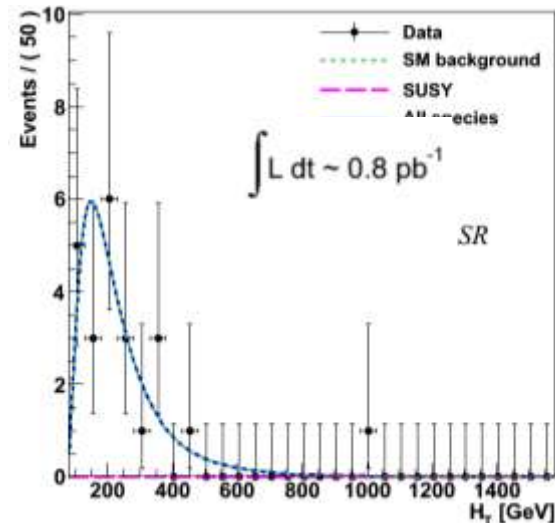
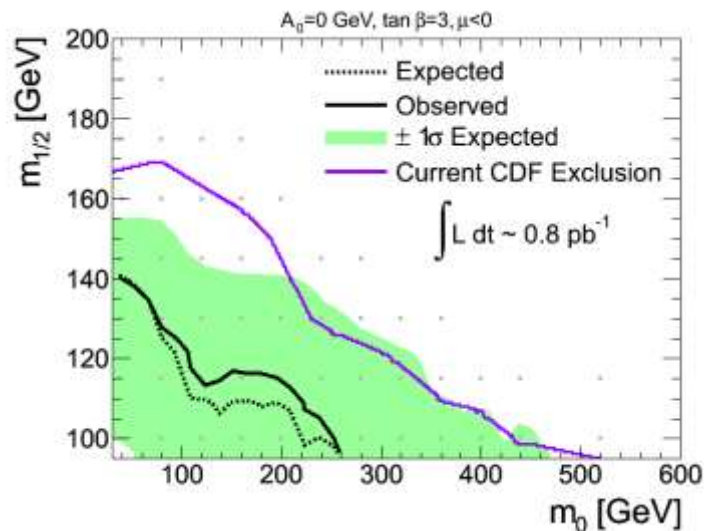

# Near Term Physics Goals for *Task H-1 (Wu)*

**(6) HIGGS.** We will continue to focus on Higgs searches

( Sau Lan Wu, Assistant Scientist Flores, Postdoc Fang, Quayle, Grad Students Asfandiyarov, Carrillo, Sabbatini, Wang )

## ***H*→*WW***

- The most sensitive Higgs channel for  $m_H \sim 160 \text{ GeV}$
- We will continue our study of all three topologies (0,1,2 jets)
- With  $1 \text{ fb}^{-1}$ ,  $H \rightarrow WW \rightarrow l\nu l\nu$  **alone** could exclude  **$137 < m_H < 185 \text{ GeV}$** 
  - Current exclusion (Tevatron, **all channels**):  $158 < m_H < 175 \text{ GeV}$

## ***H*→*ZZ* →*4 leptons***

- Working towards exclusion and discovery in a mass range inaccessible so far
- Develop new data-driven background estimation methods
- With  $1 \text{ fb}^{-1}$ , can exclude **~2 SM cross section** at  **$200 \text{ GeV}$**

## ***H*→ $\gamma\gamma$**

- Most sensitive channel for low mass Higgs (115-140 GeV)

***We will continue to work on the techniques needed for the proper statistical combination of all channels***

# Near Term Physics Goals for *Task H-1 (Wu)*

## (6) HIGGS

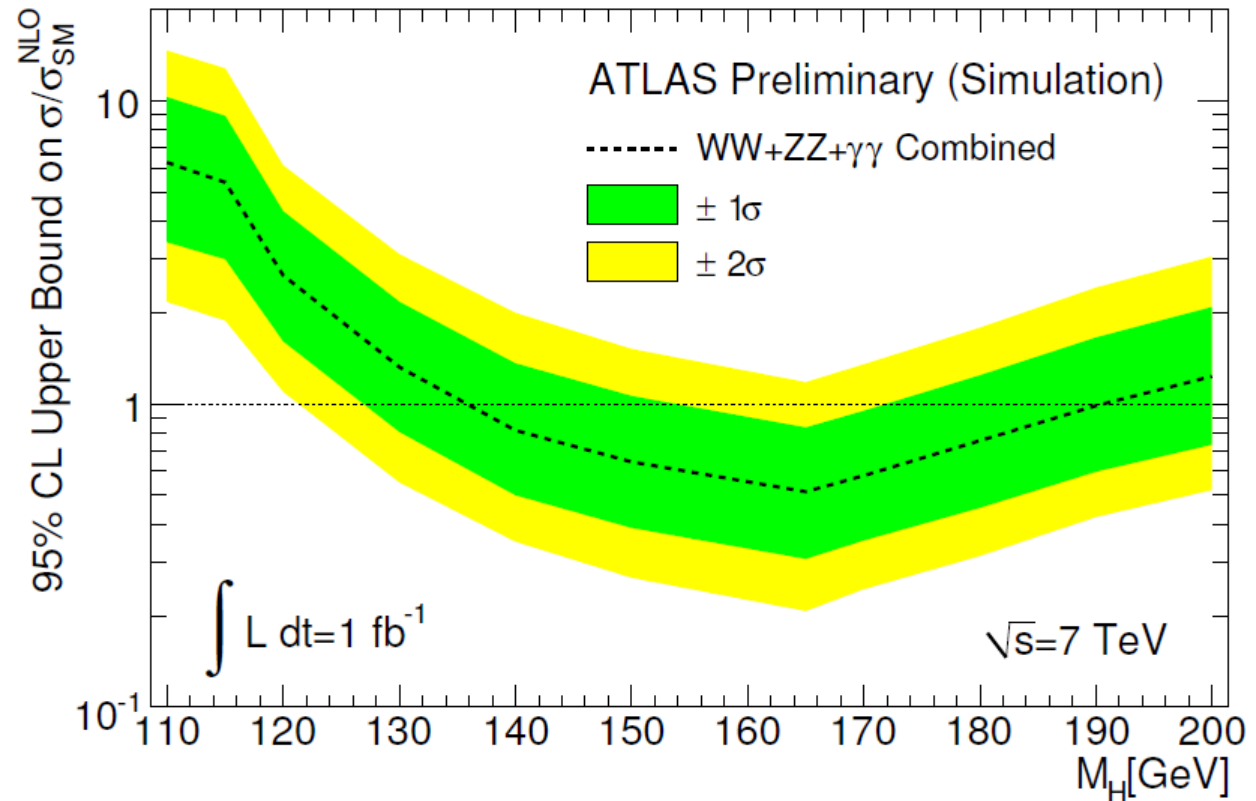

**SM HIGGS exclusion (95%CL)**

*Tevatron:*  $158 < m_H < 175 \text{ GeV}$

**$1 \text{ fb}^{-1}$  (7 TeV):  $136 < m_H < 190 \text{ GeV}$**

[ ATLAS result. Prepared by  
our postdoc W. Quayle ]

# Near Term Physics Goals for *Task H-1 (Wu)*

## *(7) Topological searches*

(Sau Lan Wu, Assistant Scientist Flores, Postdocs Poveda and Sarangi and Grad. Student Ji).

- Automatic, model-independent, search for deviations from Standard Model expectations
- For a large number of the event topologies that can be reconstructed by ATLAS
  - “Topology”: specific combination of reconstructed physics objects; for example, three leptons of the same charge and flavor.
- We will pursue this line of work to identify topologies for which the Standard Model predicts very low backgrounds with the 7 TeV data.
- It will provide us an early indication of potential new physics signals.

# Near Term Physics Goals for *Task H-1 (Wu)*

## (8) PILE UP

(Grad Student Ruslan Asfandiyarov)

- With recent luminosity  $> 10^{30} \text{cm}^{-2} \text{s}^{-1}$  pile-up is a real effect in data and presents complication for many physics analyses.
- In recent data more than 40% of events contain extra collisions. On average there are  $\sim 2$  primary vertices in every event.
- The energy of signal jets can be altered by up to 3-4%.
- *It is possible to effectively reject jets from pile-up collisions using association of tracks to vertices (Jet-Vertex-Fraction)*

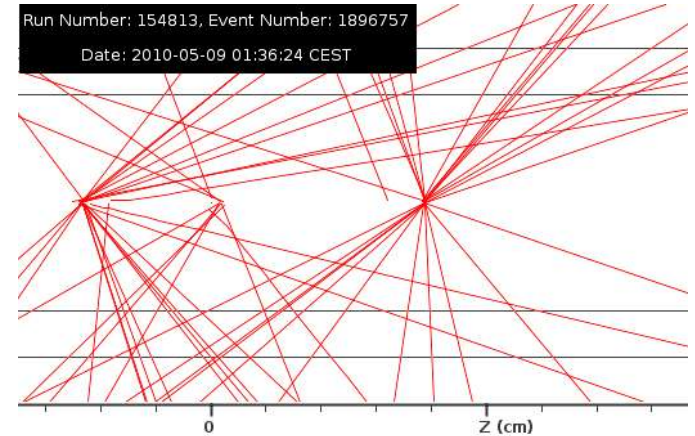

run period	peak beam intensity <sup>1</sup> [10 <sup>11</sup> ]	peak instantaneous luminosity [10 <sup>30</sup> cm <sup>-2</sup> s <sup>-1</sup> ]	number of colliding bunch pairs	average number of collisions <sup>2</sup>
D1	2.3	0.8	2	1.96
D2	3.6	1.1	4	2.00
D3	7.6	0.9	6	1.91
D4	7.1	1.4	8	2.03
D5	6.5	1.2	8	2.00
D6	7.3	1.6	8	2.04

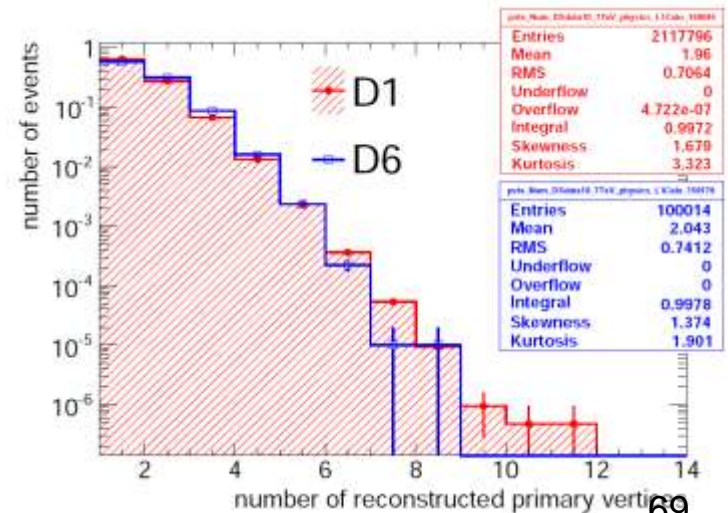

# Near Term Physics Goals for *Task H-1 (Wu)*

## (8) *PILE UP* (Grad Student Ruslan Asfandiyarov)

### effect of pileup on jet veto

- If we veto events with two or more high  $p_T$  jets, we can partially recover events rejected because of pileup.

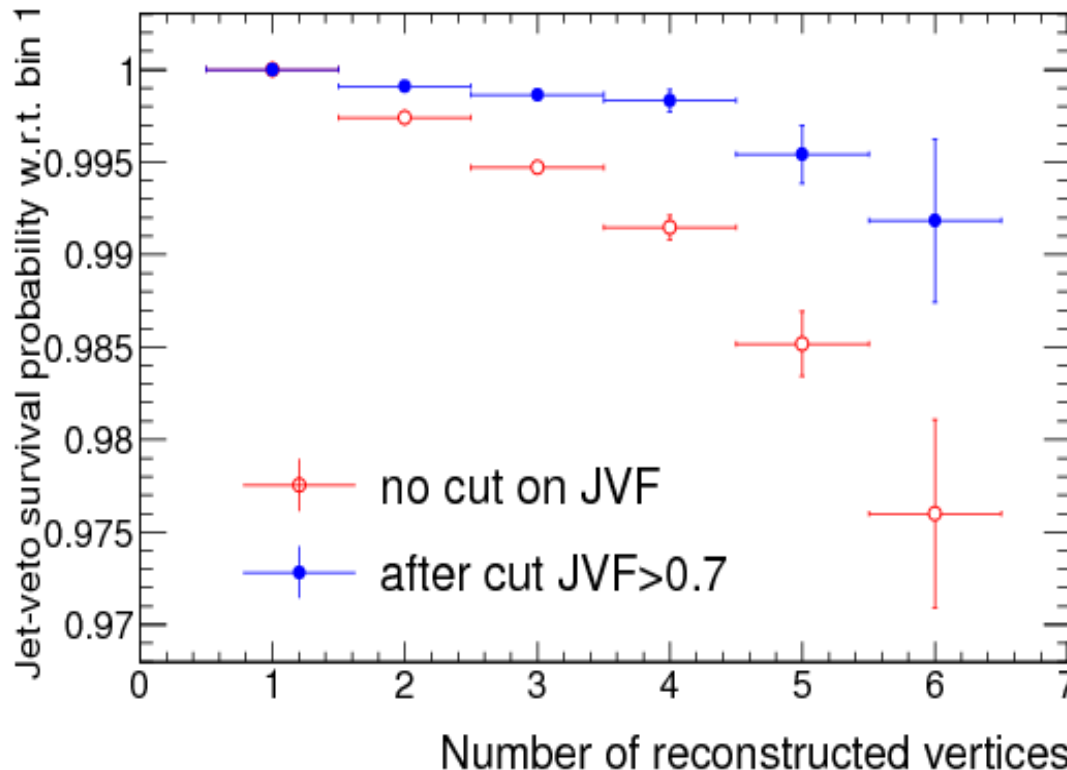

Jet Vertex Fraction (JVF)

- *JVF* is the sum  $p_T$  of all matched-tracks from a given vertex divided by the total jet-matched track  $p_T$ .

## Near Term Physics Goals for *Task H-1 (Wu)*

**(9) THESESES** expected to be completed during the period 2010-2013/14 using ATLAS data (thesis advisor Sau Lan Wu)

- **H. Wang**, “Search for Higgs bosons and Gravitons decaying into diphotons with 7TeV data”
- **H. Ji**, “Search for TeV-Scale Gravity effects (String Balls, Microscopic Black Holes) with 7TeV data”
- **E. Castaneda**, “Search for a dilepton resonance with 7TeV data”
- **A. Castaneda**, “Search for Supersymmetric particles with 7TeV data”
- **R. Asfandiyarov**, “Search for Higgs bosons in  $H \rightarrow WW$  to dileptons with 7TeV data”
- **G. Carrillo**, “Search for Higgs bosons in  $H \rightarrow ZZ \rightarrow 4$  leptons with 7TeV data”
- **L. Sabbatini**, “Search for Higgs bosons in  $H \rightarrow WW$  to lepton and hadrons with 7TeV data”
- **S. Yang**, “Search for  $W'$  and  $Z'$  resonances with 7TeV data”

***Education is one of our primary missions.***

## Near Term Physics Goals for *Task H-1 (Wu)*

- CERN is considering a new plan of running at 8 TeV in FY11. This will be discussed in the LHCC meeting in September.
- In FY12 : Publications on physics results with 7 TeV data and preparation for the 14 TeV run
- ***FY13 and after***
  - ***Search for SUSY and Higgs with 14 TeV data.***
  - ***Other discovery physics.***
- **We cannot predict what data will bring**
  - Running conditions may change rapidly.
  - New physics topics may pop up in front of us.
  - Both findings and running conditions may strongly influence our planning. We are prepared to adjust our direction accordingly.

Our contribution to detector and services – Present and future

*TASK H-1 (Wu)*

**High Level Trigger**

# Wisconsin's Contribution in the High Level Trigger

## The ATLAS Trigger System

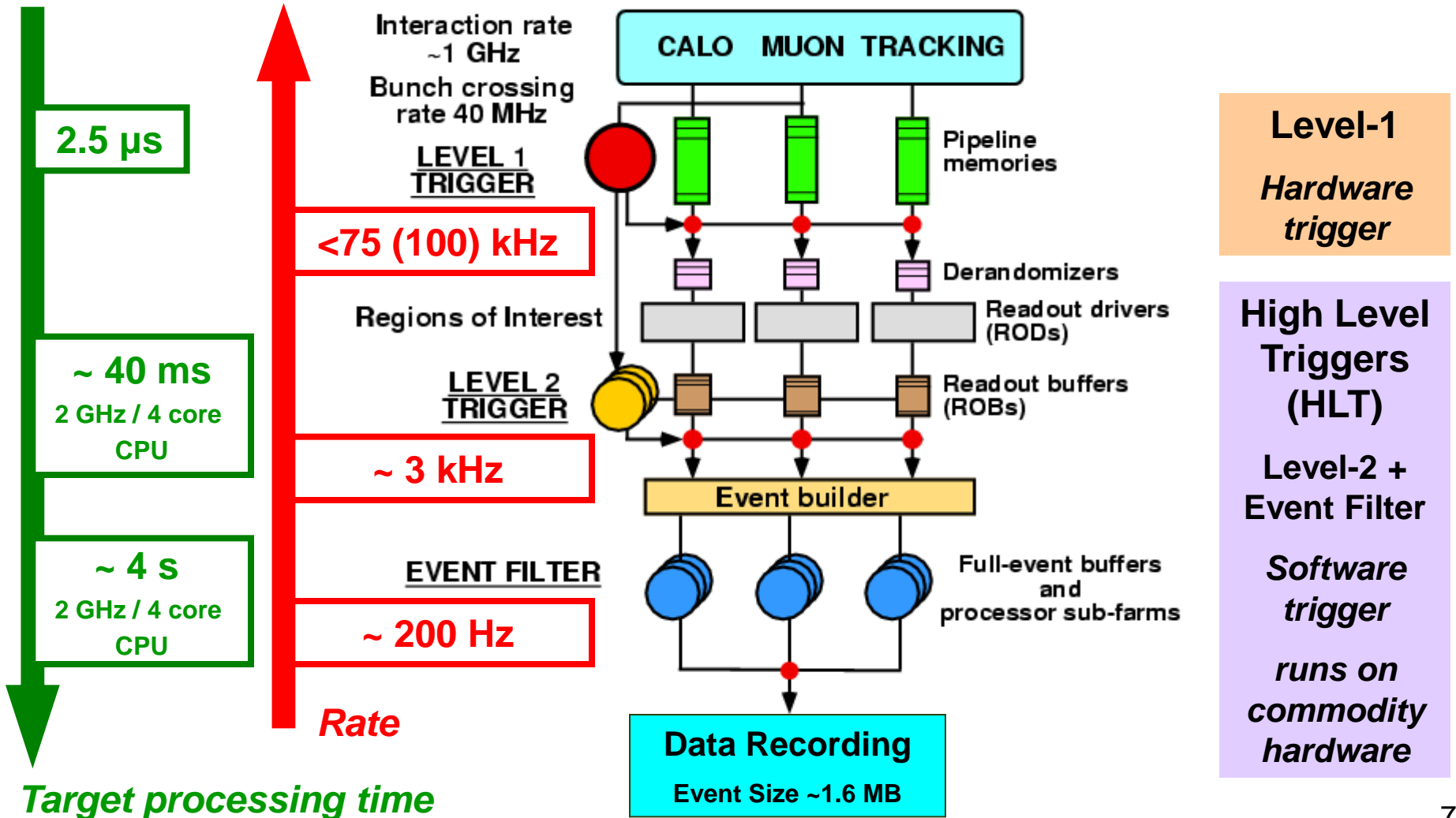

# Wisconsin's Contribution in the High Level Trigger

## The ATLAS Trigger System

### Wisconsin contribution:

- **Read Out Drivers** for the Silicon Detector
- High Level Trigger **run control** and **event selection framework**

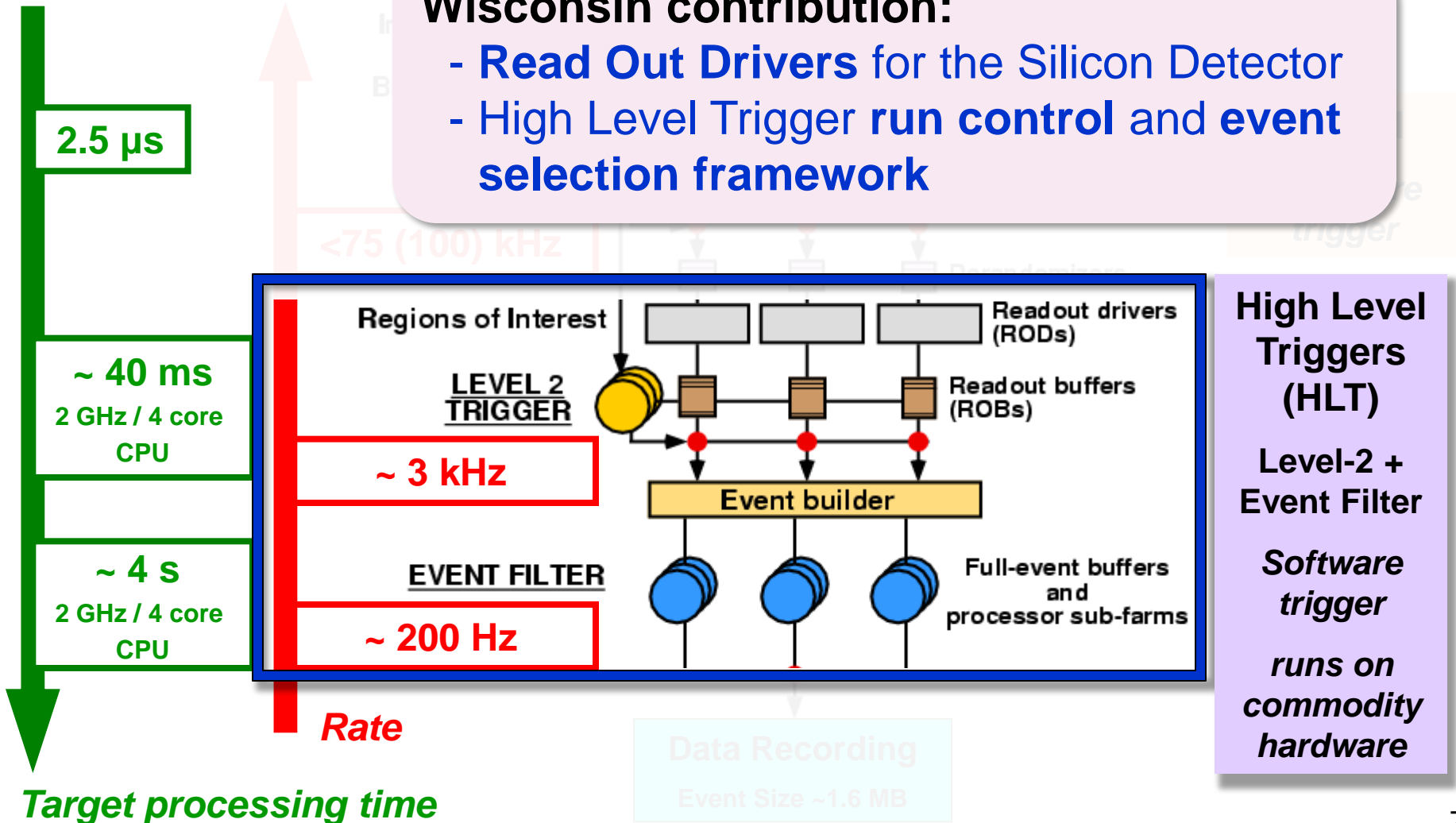

# Wisconsin's Contribution in the High Level Trigger

## Effort since 1994

*Design, Development & Maintenance of the ATLAS Event Format Library*

All subsystems use the library to en/decode their raw data

*Design, Development & Maintenance of the HLT Application Control Framework*

Run control interface for HLT applications

*Design, Development & Maintenance of the HLT Event Selection Framework*

Basic HLT selection code environment. Provides common algorithm interfaces for online and offline

*Development of HLT Algorithm Integration Strategy*

Provide:

Algorithm integration, debugging and reprocessing tools.

Partition generation tools

Automatic testing and analysis tools for multi-node trigger setups

*Trigger Monitoring and Validation*

Software for automatic release tests  
Automatic trigger validation tools  
Trigger performance monitoring

*Responsibility for L2 farm operation*

L2 segment generation & maintenance

# Wisconsin's Contribution in the High Level Trigger

**Effort since 1994**

**Design,  
Development &  
Maintenance of  
the ATLAS Event  
Format Library**

**All subsystems  
use the library  
to en/decode  
their raw data**

**Design,  
Development &  
Maintenance of the  
HLT Application  
Control Framework**

**Run control  
interface for HLT  
applications**

**Design, Development  
& Maintenance of the  
HLT Event Selection  
Framework**

**Basic HLT selection  
code environment.  
Provides common  
algorithm  
interfaces for  
online and offline**

*Development of HLT  
Algorithm  
Integration Strategy*

*Provide:*

*Algorithm  
integration,  
debugging and  
reprocessing  
tools.*

*Partition  
generation tools*

*Automatic testing  
and analysis  
tools for multi-  
node trigger  
setups*

**RAW DATA  
FORMAT**

**HLT APPLICATION  
RUN CONTROL**

**HLT SELECTION  
FRAMEWORK**

**Key components**

*Responsibility for L2 farm operation*

*L2 segment generation & maintenance*

# Wisconsin's Contribution in the High Level Trigger

**Effort since 1994**

**Support for daily operations**

*Design, Development & Maintenance of the ATLAS Event Format Library*

All subsystems use the library to en/decode their raw data

*Design, Development & Maintenance of the HLT Application*

Con...  
F...  
inter...  
applications

*Design, Development & Maintenance of the HLT Event Selection Framework*

Selection  
onment.  
Common  
algorithm  
interfaces for  
online and offline

**Development of HLT Algorithm Integration Strategy**

**Provide:**

**Algorithm integration, debugging and reprocessing tools.**

**Partition generation tools**

**Automatic testing and analysis tools for multi-node trigger setups**

**Trigger Monitoring and Validation**

**Software for automatic release tests  
Automatic trigger validation tools  
Trigger performance monitoring**

**Responsibility for L2 farm operation**

**L2 segment generation & maintenance**

# Wisconsin's Contribution in the High Level Trigger

## Trigger operations

All Wisconsin-provided components have been successfully used in **all ATLAS data-taking campaigns**

- From **early commissioning w/cosmics** to **routine data-taking w/LHC**
- **High data-taking efficiency (avg. 96.5% March to August 2010)**
- Especially appreciated: **pre-scales and conditions data can be changed without stopping the run**

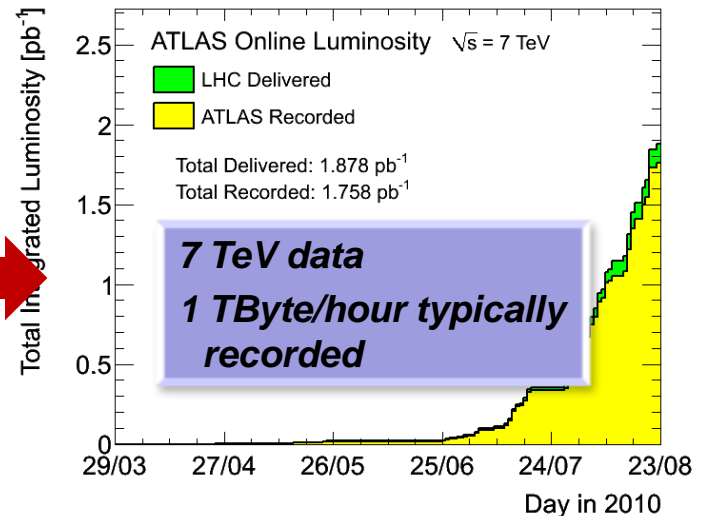
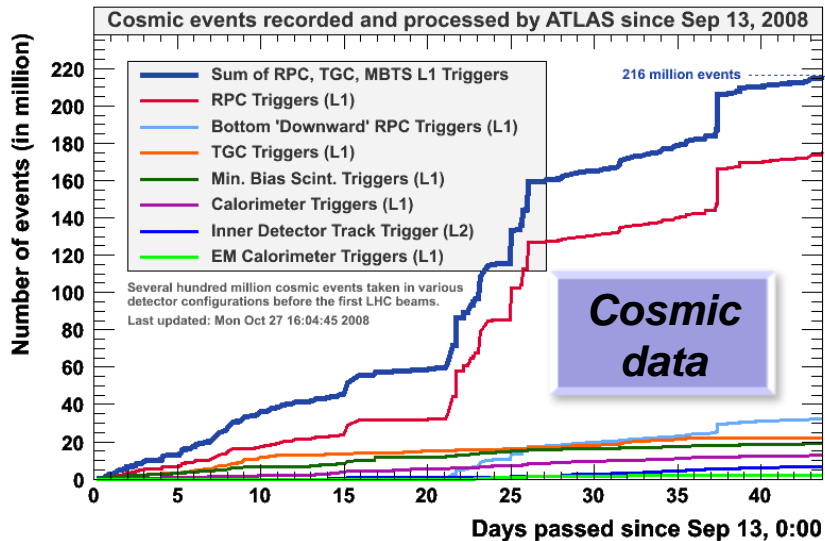

# Wisconsin's Contribution in the High Level Trigger

## HLT Processor Evaluation and Commissioning

**Wisconsin is responsible for:**

- **Benchmarking new processor models** with HLT code and performance suites
- **Commissioning all HLT processors**
  - 2008: ~ **720** machines
  - 2010: ~ **320** machines
- Important contribution from Wisconsin students for **commissioning shifts**

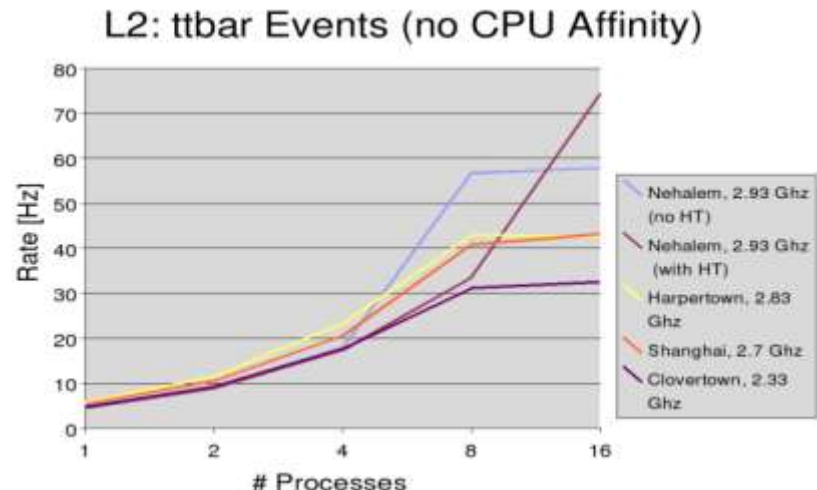

# Wisconsin's Contribution in the High Level Trigger

## Contributions to Trigger Tasks

- Development and maintenance of software for **trigger monitoring** in nightly release tests  
(grad. Student A. Castaneda)
- Development of trigger **validation tools** (postdoc W. Quayle)
- Development and maintenance of software for **validating the LAr cell energy** in online and offline  
(postdoc T. Sarangi)
- Monitoring of trigger performance for
  - e/ $\gamma$  selection (grad. Student H. Wang)
  - b-physics (postdoc Ma and grad. Student H. Ji)
  - J/ $\psi$  selection (grad. Student H. Ji)

# Wisconsin's Contribution in the High Level Trigger

## Data Flow Evolution Prototype

- For **ATLAS upgrades**, development of new system architectures
- A **first prototype**, created under our leadership, is **already in use** to measure critical dataflow parameters

Combine L2 and EF in one HLT processing unit

Block diagram

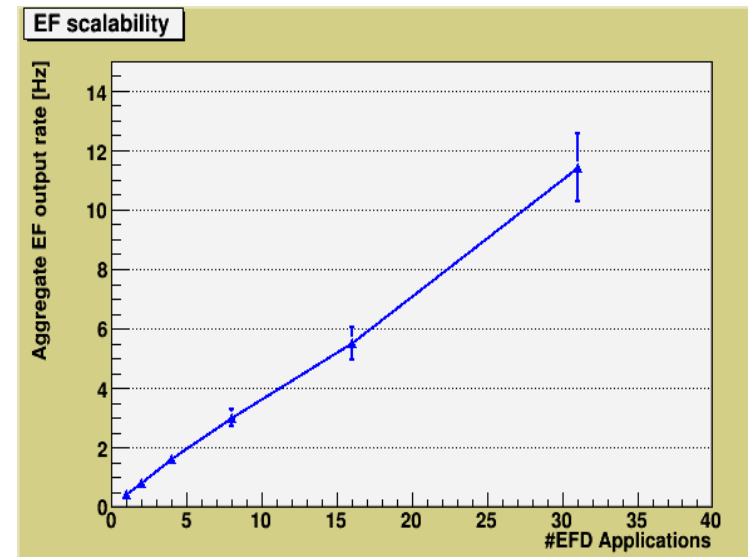
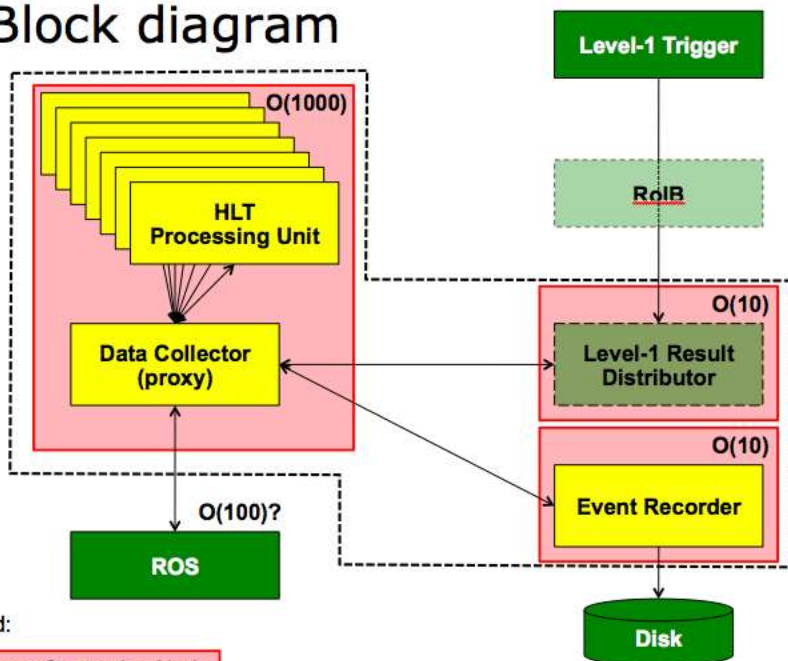

Scalability tests on ATLAS dataflow test cluster show expected **scaling with number of selection applications** 82

Our contribution to detector and services – Present and future

***TASK H-1 (Wu)***

**Silicon ROD's**

# The Silicon Read-Out Driver (ROD)

- Interfaces the Silicon detectors in ATLAS with the Trigger and Data Acquisition systems.

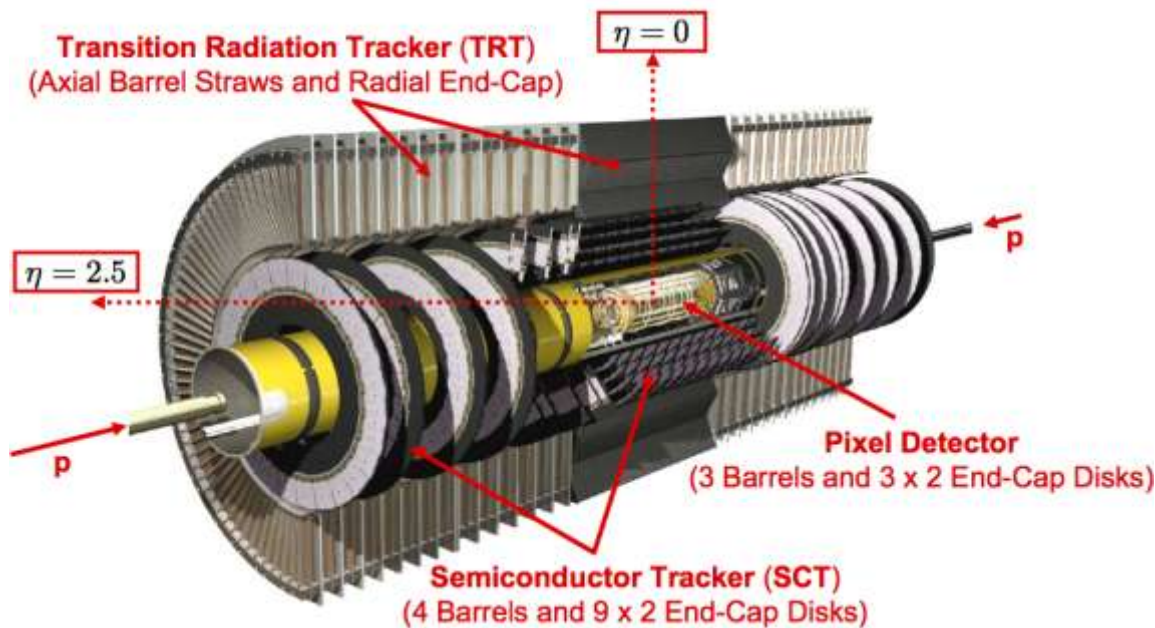

## Silicon detectors:

- Closest to the interaction point.
  - Pixel Detector inside the Semiconductor Tracker (SCT).
  - Critical for charged-particle tracking, B hadron tagging and  $\tau$ -lepton tagging.
- Wisconsin has been responsible for 100% of the ROD's. Including design, production and maintenance of the hardware, firmware and software.

# The Silicon Read-Out Driver (ROD)

► A hybrid of FPGAs and DSPs

← Configuration & Triggers  
 → Event Data  
 ← Backpressure / Halt Output

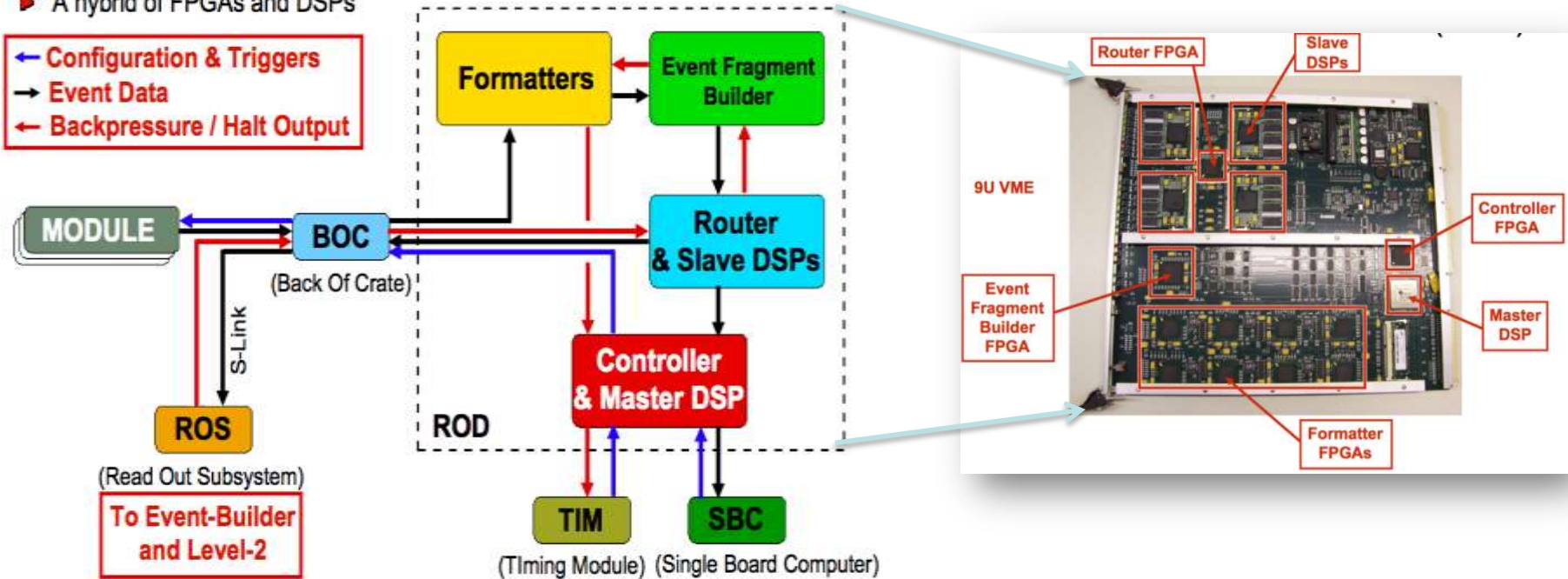

- Wisconsin has built 270 ROD's
- Each ROD supports a large number of detector channels:
  - Up to 48 SCT modules [total: 4088 modules, **6.2 million** channels]
  - Up to 32 Pixel modules [total: 1744 modules, **80 million** channels]
- Purpose: - **Module configuration, trigger propagation, data formatting.**  
 - **Calibrations, monitoring**

# The Silicon Read-Out Driver (ROD)

## *Recent activity*

- Wisconsin has provided hardware, firmware and software support for the RODs
- The pixel and SCT RODs are 100% operational
- Contributions
  - SCT ROD Digital Signal Processors' code
  - ROD boards repair
  - Firmware development for SCT and Pixels
  - Full detector calibration procedures, ensuring low dead time and safe operation
  - SCT detector operation: more than 500 hours shifts

# The Silicon Read-Out Driver (ROD)

## 7 TeV Collision

- The performance of the RODs has been crucial for data taking
- In the past 3 years
  - Over 500M cosmics in 2008-9
  - Over 450k 900 GeV collisions
  - Over 30k 2.36 TeV collisions
  - Over 400M 7TeV collisions
- The first published paper by the ATLAS Collaboration Phys.Lett.B.
- More than 20 public notes

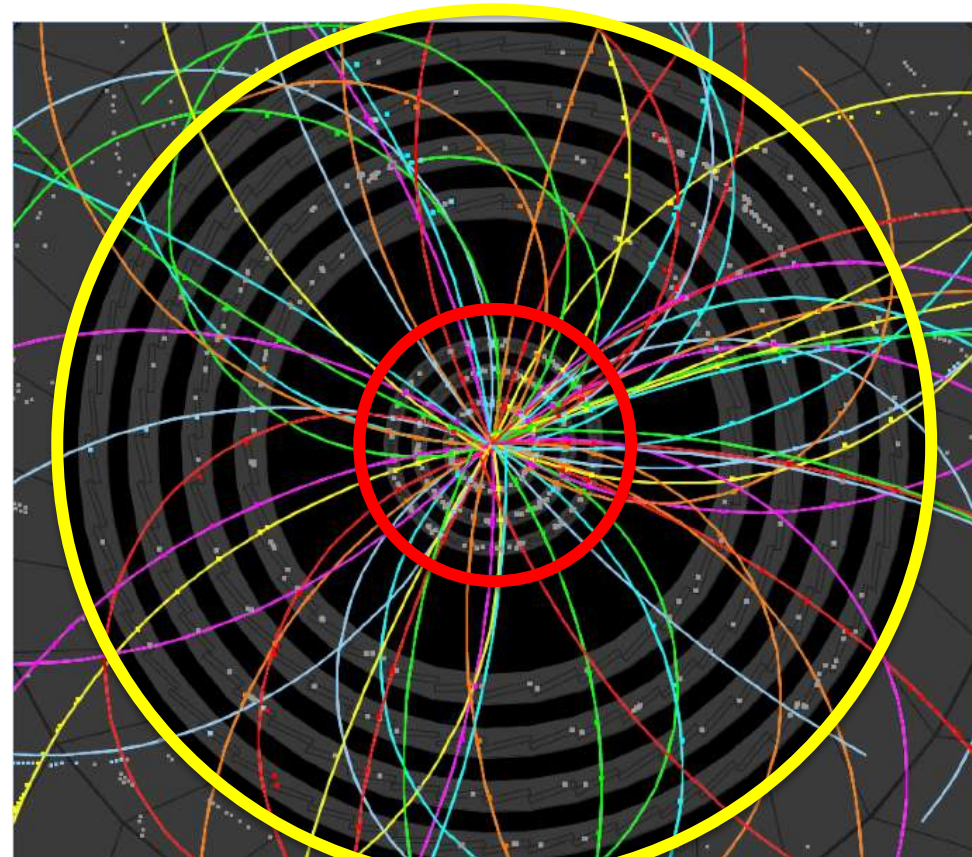

Run Number: 152166, Event Number: 451982

Date: 2010-03-30 13:28:15 CEST

○ Pixels  
○ SCT

Our contribution to detector and services – Present and future

**Computing**

# Our ATLAS Tier-3 computing facility

- We collaborate with groups in **BNL, SLAC, CERN** and the **Wisconsin Computing Science Department** to
  - strengthen our Tier-3 facility and to
  - contribute to **ATLAS Tier-3 working groups**.
- GRID-attached Tier3; a dedicated file transfer channel to BNL provides high data transfer speed (~300MB/s).
- Based on the **Condor system** and integrated in the Wisconsin computing farm (**GLOW**).
- Mainly used for ATLAS Monte Carlo production and optimized for massive data analysis activities.
- Fruitful collaboration with the PROOF team at CERN
- **Virtual dynamic Tier-3 structure**. Designed to optimize analysis over a large data pool in an existing batch system

# OUTLINE

## PART 2

- (1) **ATLAS notes with Data** *Task H-2 (Mellado, Pan)*
- (2) **Progress report of the past 3 years** *Task H ( All )*  
(2007 to March 2010) *( Mellado, Pan, Wu)*

**Contribution and future plans for hardware will be covered by B.Mellado**

**Future plans for physics analysis will be covered by Y.Pan**

**ATLAS notes with data**  
**For Task H-2 (Pan & Mellado)**

# ATLAS notes with Data *Task H-2 (Pan & Mellado)*

(Profs. Pan & Mellado, Postdoc Zhu)

- Notes with  and  are in common with Task H-1 (Wu)

## Detector performance (4 notes)

- Performance of the missing transverse energy reconstruction in minimum bias events at  $\sqrt{s}$  of 900 GeV and 2.36 TeV with the ATLAS detector, ATLAS-CONF-2010-008
- Data-Quality Requirements and Event Cleaning for Jets and Missing Transverse Energy Reconstruction with the ATLAS Detector Proton-Proton Collisions at a Center-of-Mass Energy of  $\sqrt{s} = 7$  TeV, ATLAS-CONF-2010-038
- Performance of the missing transverse energy reconstruction in minimum bias collisions at center-of-mass energy of  $\sqrt{s} = 7$  TeV with the ATLAS detector, ATLAS-CONF-2010-039
- Performance of the Missing Transverse Energy Reconstruction and Calibration in Proton-Proton Collisions at a Center-of-Mass Energy of  $\sqrt{s} = 7$  TeV with the ATLAS Detector, ATLAS-CONF-2010-057

## Physics results (4 notes)

- Observation of  $W \rightarrow \ell\nu$  and  $Z \rightarrow \ell\ell$  production in proton-proton collisions, ATLAS-CONF-2010-044
- Measurement of the  $W \rightarrow \ell\nu$  production cross-section and observation of  $Z \rightarrow \ell\ell$  production in proton-proton collisions at  $\sqrt{s} = 7$  TeV with the ATLAS detector, ATLAS-CONF-2010-051

Milestones

# ATLAS notes with Data

*Task H-2 (Pan & Mellado)*

• Notes with  and  are in common with Task H-1 (Wu)

**Measurement of the Background from W+jets to the  $H \rightarrow WW \rightarrow \ell u \ell u$  Search with the ATLAS detector at 7 TeV, ATLAS-COM-CONF-2010-084**

**Milestone, first Higgs-like note with data!**

**Tests of the data driven ZZ and Z+jets background estimation methods for the Higgs boson search in the 4-lepton final state, ATLAS-COM-PHYS-2010-611 (To appear publicly)**

## *Publications*

**Combined performance studies of the ATLAS detector using cosmic-ray muons, To be submitted to: Eur. Phys. J. C**

**Before data-taking started our group contributed to the understanding of potential non pp collision sources of fake MET, like calorimeter noise, cosmic muons. Use shower shapes and timing. Developed likelihood-based discriminator against these backgrounds:**

<https://twiki.cern.ch/twiki/bin/view/Atlas/Approved2009CosmicPlotsJetEtMiss>

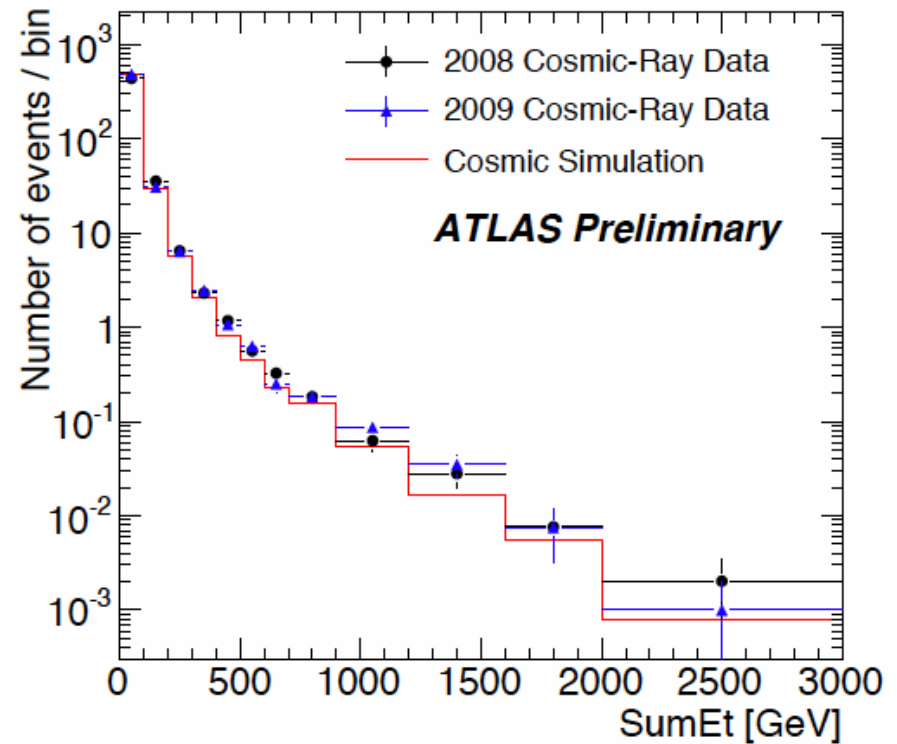
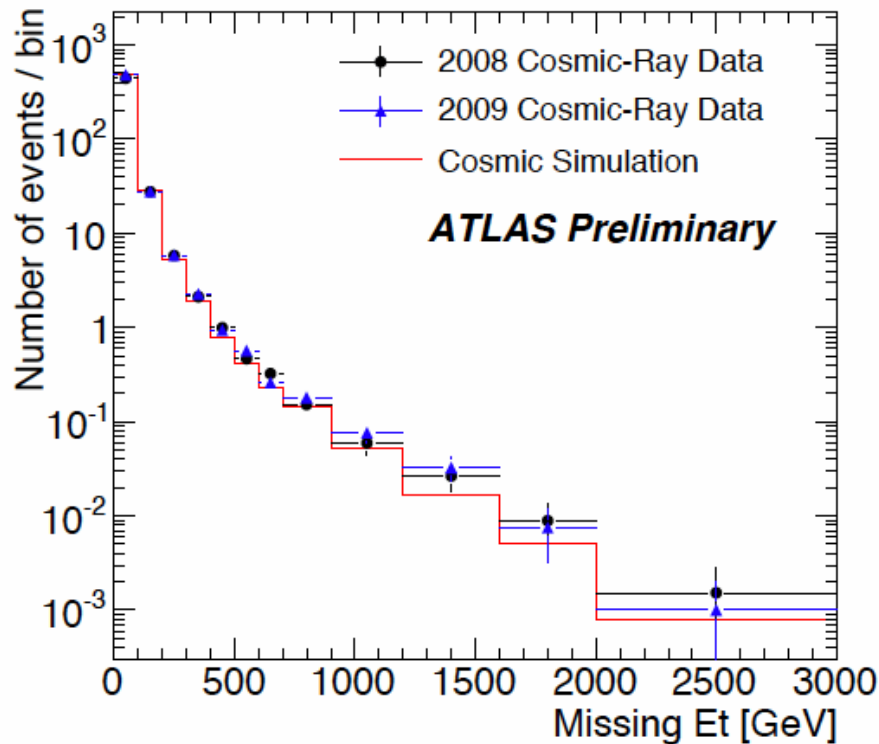

**Combined performance studies of the ATLAS detector using cosmic-ray muons**

Version: 0.95

To be submitted to: Eur. Phys. J. C

## Task H-2 (Pan & Mellado)

Based on these and 6-year long studies of the MET performance of ATLAS we made strong contribution to first MET performance studies, MET clean up...

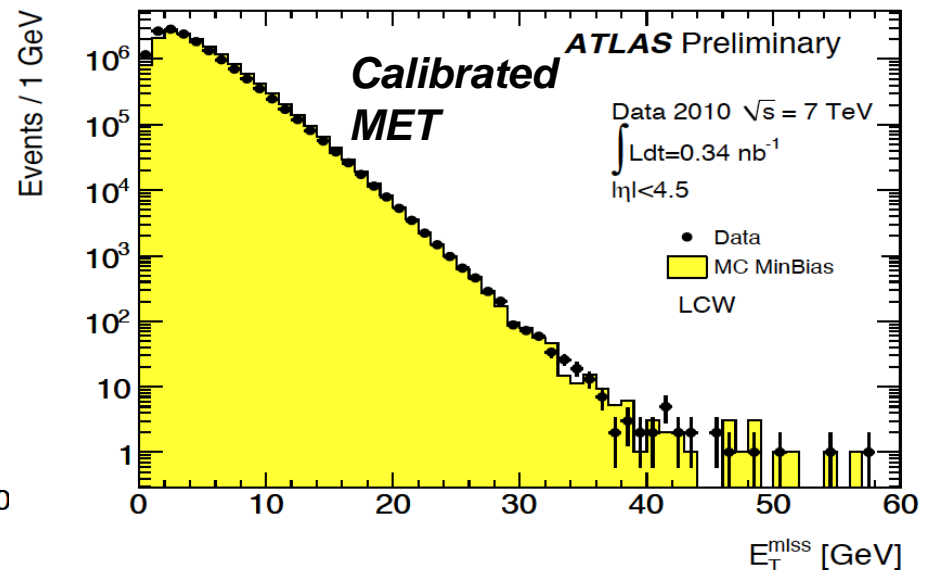
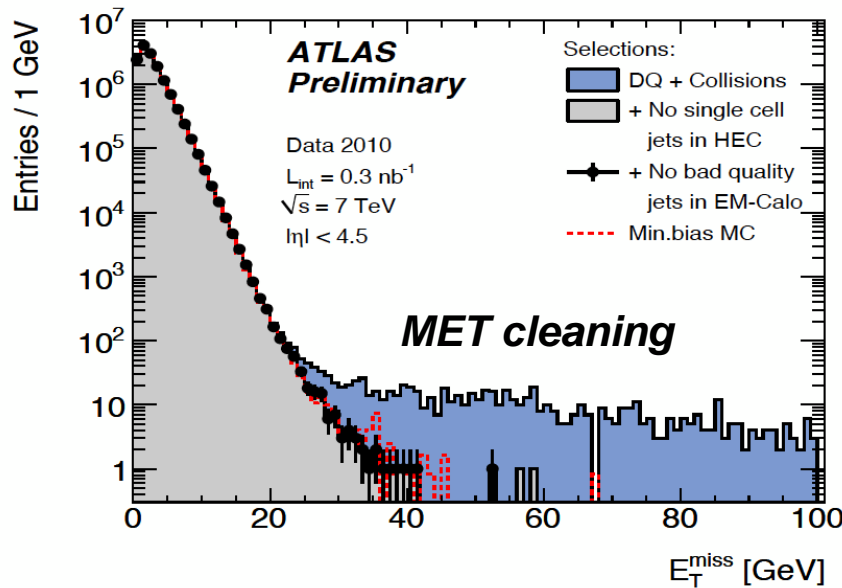
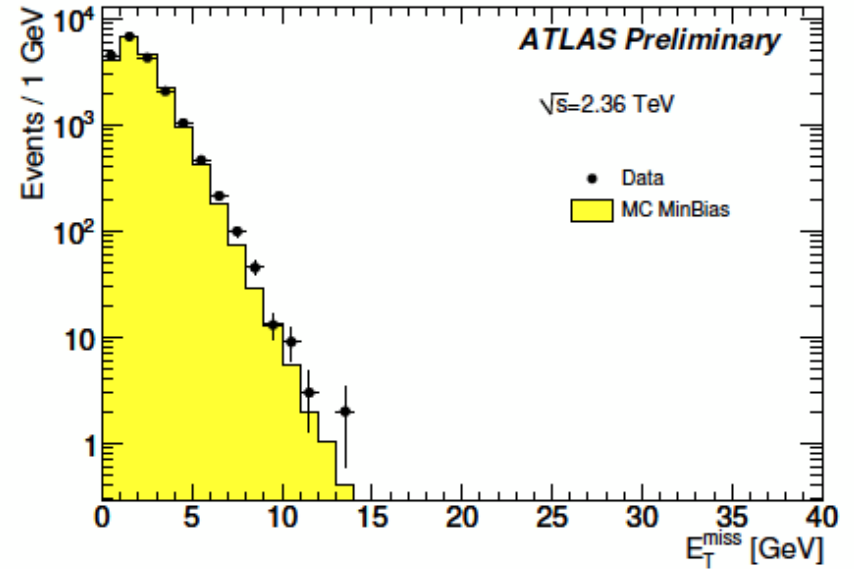
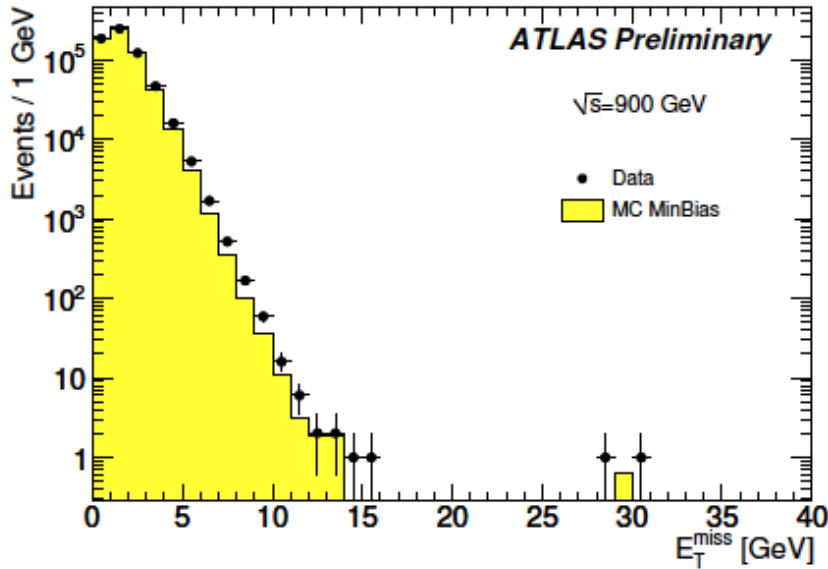

Our knowledge was applied for the first observation of the W boson at ATLAS and the first cross-section. Made sure that the MET reconstruction was robust, get full confidence in the MET reconstruction at this early stage, define MET reconstruction, evaluate contribution from fake MET, MET systematics for x-sec

**First observation of W and first cross-section**

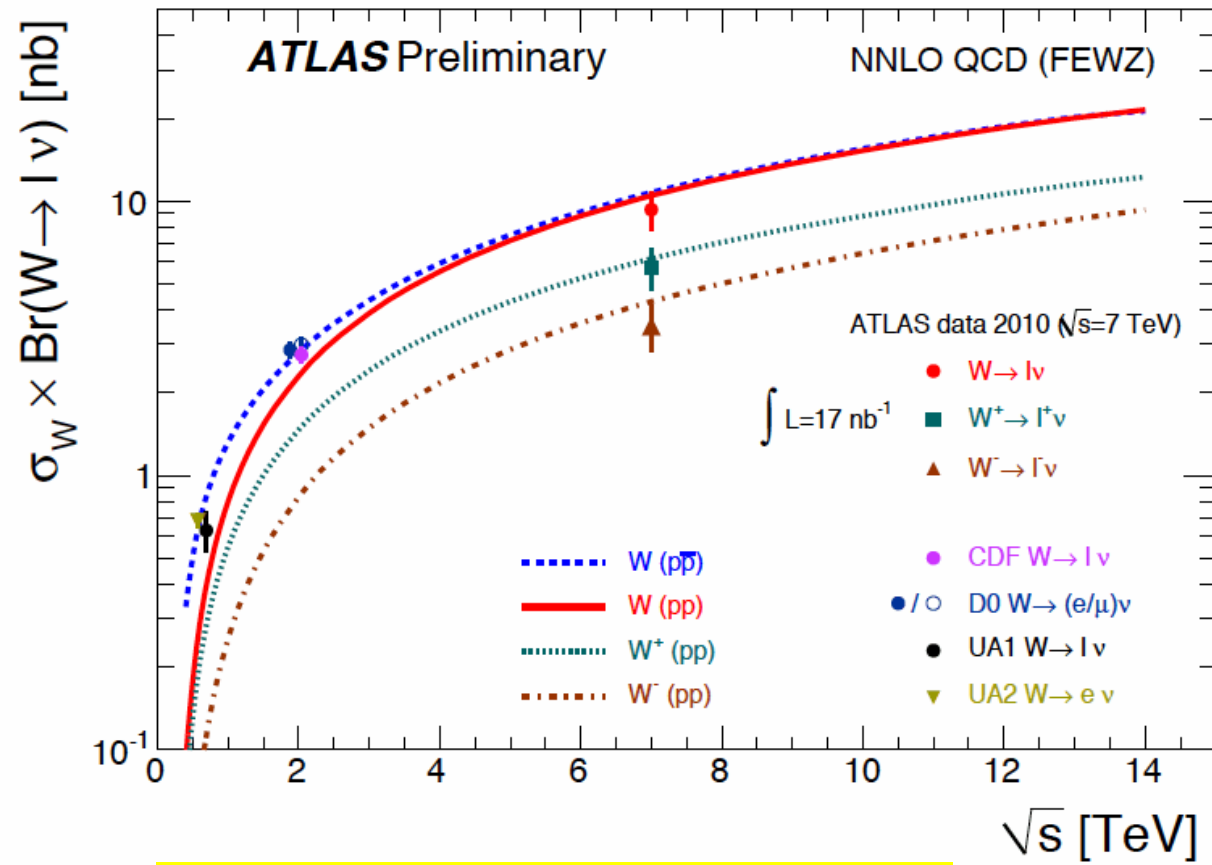
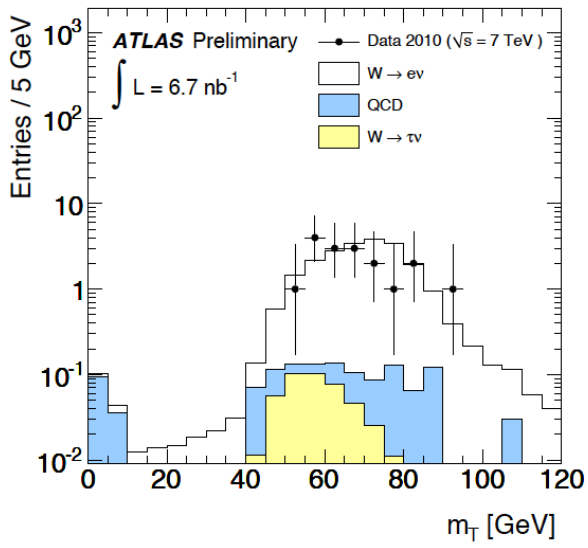
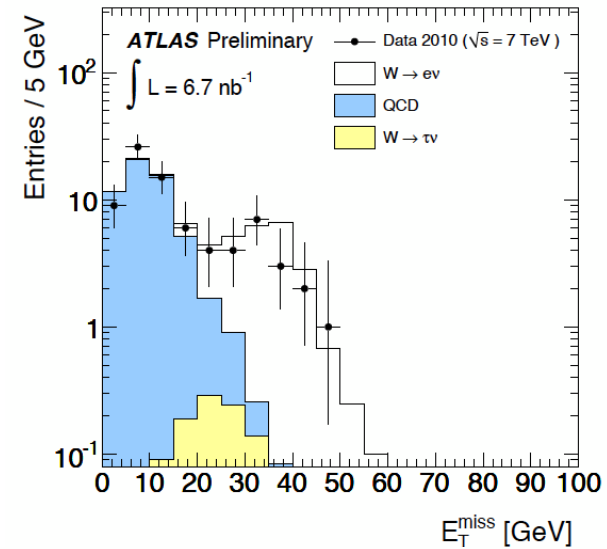

**Systematic error due to MET 2%**

# The Roadmap to the Higgs

**Task H-2 (Pan & Mellado)**

**One good lepton + one fake lepton from W+jets**



ATLAS NOTE

August 10, 2010



Measurement of the Background from  $W$ +jets to the  $H \rightarrow WW^* \rightarrow \ell\nu\ell\nu$   
Search with the ATLAS detector at  $\sqrt{s} = 7$  TeV

The ATLAS Collaboration

**Following the success in the observation of the  $W$  the Higgs WG is preparing for the first Higgs results with data: first observation of one good lepton fake lepton**

**MC agrees well with data.**

**Gives us a lot of confidence that we will be able to search for a low mass Higgs with the  $WW$  decay mode!**

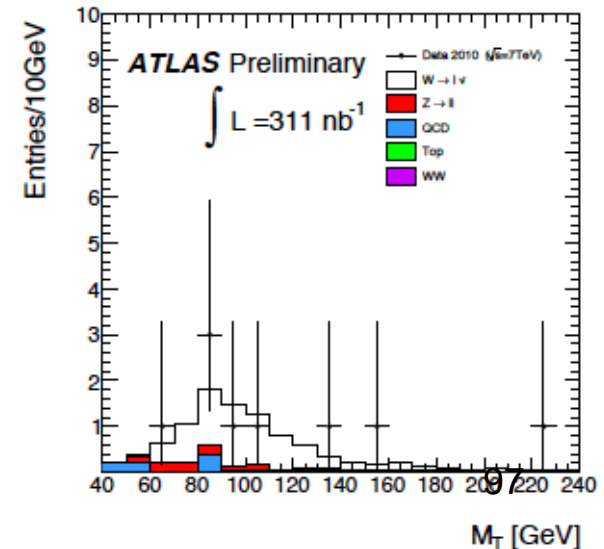
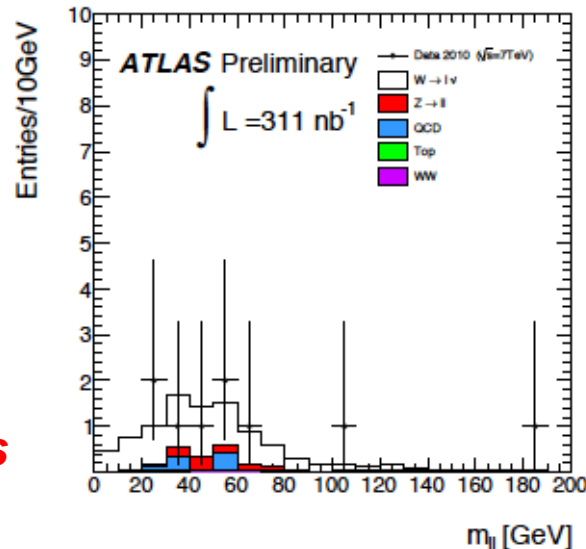
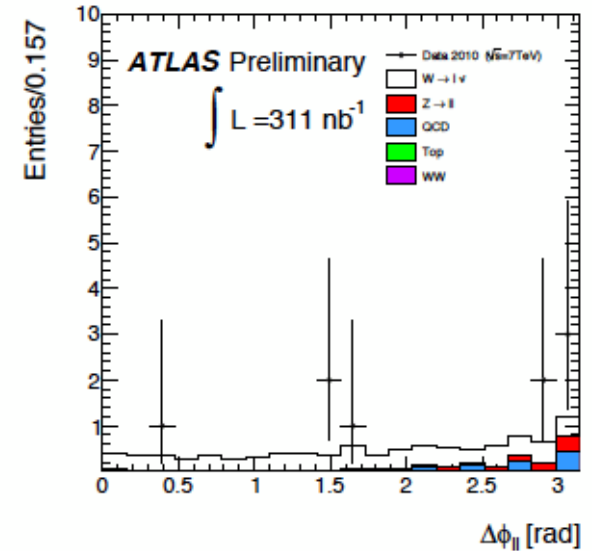
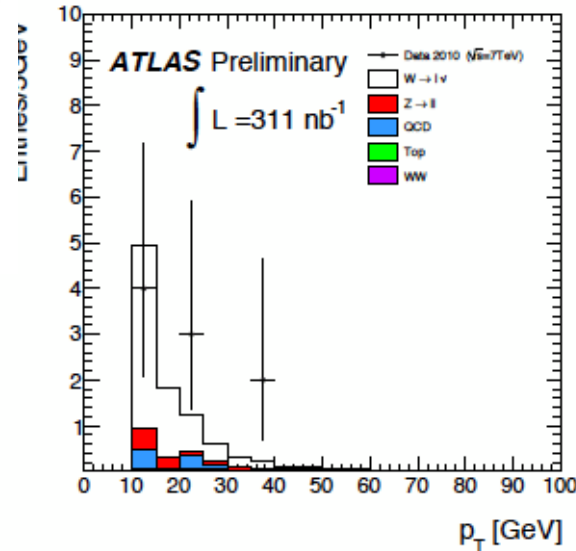

**Progress report of the past 3 years**

**For Task H (Wu, Pan, Mellado)**

**( 2007 until March 2010 )**

## ATLAS THESES (2005-2009)

- **K. Cranmer** (Goldhaber Fellow at BNL; Presidential Early Career Award for Scientists and Engineers 2007, now Assistant Professor at New York University) Searching for New Physics: Contributions to LEP and the LHC, 2005
- **K. Loureiro** (Postdoc at Ohio State University) Measuring the Photon Energy Scale Through Test Beam Data, 2006
- **A. Stradling** (Postdoc at University of Texas-Arlington) An Examination of Backgrounds to Early-Run Minimum-Bias Events in ATLAS at the LHC, 2008
- **Y. Fang** (Postdoc at University of Wisconsin-Madison) Search for SM Higgs Decaying to Two Photons via ATLAS Detector, 2008
- **W. Quayle** (Postdoc at University of Wisconsin-Madison) Searches in the  $H \rightarrow WW$  Decay Mode Using the ATLAS Detector, 2008
- **X. Chen** (Postdoc at University of Wisconsin-Madison) Reconstruction of the missing transverse energy and search for a SM Higgs boson via VBF in the di-tau decay with ATLAS", 2009

# Education

- ***Training of Graduate Students:***

**48 Grad. students have obtained Ph.D. degrees from this task:  
10 in TASSO, 22 in ALEPH, 10 in Babar and 6 in ATLAS  
( 43 from Sau Lan Wu, 2 from Yibin Pan, 3 from Bruce Mellado)**

- ***Faculty Positions of Former Postdocs and Grad Students***

**27 Former Postdocs and Graduate Students are (or have been) faculty members mainly in major U.S. universities (12 are in ATLAS, 4 in CMS).**

**9 are permanent staff members at major High Energy laboratories.**

# Education: Training of Graduate Students

10 TASSO  
22 ALEPH  
10 BaBar  
6 ATLAS

48 Grad. students have obtained Ph.D. degrees from this task:

1) J. Freeman	1981	Fermilab	25) P.Elmer	1998	Princeton
2) T. Barklow	1983	Stanford	26) S. Armstrong	1998	CERN Fellow
3) E. Wicklund	1984	Caltech	27) W. Orejudos	1998	Berkeley
4) H. Venkataramania	1985	Yale	28) X. Wu	1998	SBC Communications
5) D. Strom	1986	Chicago	29) O. Hayes	1999	Booz Allen Hamilton Consulting
6) M. Cherney	1987	Berkeley	30) T. Greening	1999	CERN Fellow
7) A. Caldwell	1987	Columbia	31) D. Ferguson	2001	Wisconsin
8) S. Ritz	1988	Columbia	32) J. Nielsen	2001	Berkeley
9) D. Muller	1989	Stanford	33) E. Charles	2002	Berkeley
10) M. Takashima	1989	CERN Fellow	34) P. McNamara	2002	Rutgers
11) D. Cowen	1990	Caltech	35) S. Sekula	2004	MIT
12) J. Hilgart	1991	CERN Fellow	36) R. Liu	2004	Berkeley Business School
13) J. Boudreau	1991	CERN Fellow	37) J. Wu	2004	Harvard
14) J. Wear	1991	U.C.SantaCruz	38) Z. Yu	2005	Clear Shape Technologies
15) Y. Pan	1991	Wisconsin	39) B. Cheng	2005	Avestar-IP
16) D. Cinabro	1991	Wisconsin	40) A. Mihalyi	2005	Princeton Consulting
17) J. Pater	1993	CERN Fellow	41) K. Cranmer	2005	BNL
18) F. Weber	1995	CERN Fellow	42) M. Datta	2005	FNAL
19) M. Walsh	1995	Rutgers	43) K. Loureiro	2006	Ohio State
20) L. Bellantoni	1995	FNAL Wilson Fellow	44) P. Kutter	2006	Citizen's Insurance
21) Z. Feng	1995	John Hopkins	45) A. Stradling	2008	Texas Arlington
22) Y. Gao	1995	Harvard	46) W. Quayle	2008	Wisconsin
23) J. Nachtman	1997	FNAL Wilson Fellow	47) Y. Fang	2008	Wisconsin
24) J. Grahl	1998	Iowa State	48) X. Chen	2009	Wisconsin

# Education: Faculty Positions of Former Postdocs and Grad Students

27 Former Postdocs and Graduate Students are (or have been) faculty members mainly in major U.S. universities and 10 are permanent staff members at major High Energy laboratories. (13 full prof., 8 associate prof. with tenure, 5 assistant prof. and 1 former assistant prof.)

## Full Professors

1. Robert Johnson	• UC Santa Cruz
2. Steven Ritz	• UC Santa Cruz
3. Vivek Sharma	• UC San Diego
4. Allen Caldwell	• Columbia University
5. David Strom	• University of Oregon
6. Yuanning Gao	• Tsinghua Univ. in Beijing
7. Michael Cherney	• Creighton Univ.
8. Joe Izen	• Univ. of Texas, Dallas
9. Shan Jin	• IHEP, Beijing
10. Hongbo Hu	• IHEP, Beijing
11. John Harton	• Colorado State Univ.
12. Haibo LI	• IHEP, Beijing
13. David Cinabro	• Wayne State Univ.

## Associate Professors with tenure

14. Joe Boudreau	• Univ. of Pittsburg
15. Doug Cowen	• Penn. State Univ.
16. Gerald Rudolph	• Universitat Innsbruck
17. Yibin Pan	• Univ. of Wisconsin
18. Michael Schmitt	• Northwestern Univ.
19. John Conway	• UC Davis
20. Stathes Paganis	• Lecturer at Sheffield Univ.
21. Jane Nachtman	• Univ. of Iowa

## Assistant Professors

22. Yongsheng Gao	• California State Univ.-Fresno
23. Tom Meyer	• Formerly at Texas A&M
24. Bruce Mellado	• Univ. of Wisconsin
25. Jason Nielsen	• UC Santa Cruz
26. Kyle Cranmer	• New York University
27. Stephen Sekula	• Southern Methodist

ATLAS: 12

CMS: 4

ALICE: 1

## Permanent Staff at Major Research Laboratories

Former Postdocs	1. <b>Saul Gonzalez</b>	• <b>Program Manager for Proton Accelerator Physics, Physics Research division of Office of High Energy Physics, DOE</b>
	2. <b>Pierre Lecomte</b>	• <b>Staff Physicist, ETH (Switzerland)</b>
	3. <b>Tom C.Meyer</b>	• <b>Staff Physicist at CERN</b>
	4. <b>John Walsh</b>	• <b>Researcher, INFN, Italy</b>
Former Students	5. <b>James Freeman</b>	• <b>Scientist II, FNAL</b>
	6. <b>Tim Barklow</b>	• <b>Staff Physicist at SLAC</b>
	7. <b>David Muller</b>	• <b>Staff Physicist at SLAC. Now at DOE</b>
	8. <b>Eric Wicklund</b>	• <b>Staff Physicist at Fermilab</b>
	9. <b>Leo Bellantoni</b>	• <b>Scientist I, FNAL</b>

# TECHNOLOGY TRANSFER

An interesting development is that high energy physicists are entering the workforce of well-known industries. Having been well trained in the high technology environment of large international physics collaborations, members of our group are extremely well suited to provide the functionality of technology transfer, always on the leading edge. For example, former postdocs and students who now hold positions in companies are:

1. Ian Scott – Director of Client Services at Angoss Software
2. John Yamartino – Engineering Program Manager at Applied Materials, Inc., Silicon Valley
3. Makoto Takashima – Executive Director in Equities Division at Morgan Stanley in London
4. Zhong Feng – Lead System Engineer at Raytheon for NASA/Goddard Space Flight Center
5. John Hilgart – eCommerce Infrastructure Architect at BASF Corporation
6. Fred Weber – Senior Research Scientist at ScanSoft, Inc. (Boston) for speech recognition
7. Jim Wear – Senior Scientist at GE Medical Systems
8. Michael Walsh – Superior Consulting Company Inc.
9. Xidong Wu – Software Engineer at SBC Communications (now at AT&T)
10. Owen Hayes – Senior Associate at Booz Allen Hamilton Consulting Firm
11. Thomas Greening – Principal Scientist at Honeywell; recipient of Technical Achievement Award (2003) and Outstanding Engineer of the Year Award (2002) (*Now in Apple Inc.*)
12. Zhitang Yu – Research and Development Engineer at ClearShape Technologies
13. Baosen Chen – Software Engineer at Avestar-IP
14. Attila Mihalyi – Senior Associate/Consultant at Princeton Consultants
15. Jinwei Wu – Goldman Sachs

# DETECTOR PERFORMANCE AND SOFTWARE DEVELOPMENT

- ***MISSING TRANSVERSE ENERGY RECONSTRUCTION***  
(Profs. S.L.Wu, Pan and Mellado, Assist. Scientist Flores and Grad. Student X. Chen)  
The object-based algorithm, developed by our group, has been integrated into the ATLAS MET software package.
- ***SUPPRESSION OF FAKE MISSING ENERGY FROM COSMIC RAYS***  
(Profs. S.L. Wu, Pan and Mellado, Postdocs Zhu, Peng)  
Suppression of Fake Missing Transverse Energy from Cosmic Ray Muons in the ATLAS Calorimeter, Mellado, Peng, S.L.Wu, Zhu (Wisconsin), Assamagan(BNL), Valls(Valencia), ATL-PHYS-INT-2010-028
- ***HIGH PT JET ENERGY CALIBRATION***  
(Postdoc Poveda, Peng and Grad. Student Ji)  
Data-driven calibration of high- $p_T$  jets with the multijet balance method.
- ***CALORIMETER-BASED MUON IDENTIFICATION***  
(Assist. Scientist Flores)  
Crucial for recovering muons in regions where the muon chambers have a reduced efficiency

# DETECTOR PERFORMANCE AND SOFTWARE DEVELOPMENT

- **ELECTRON CALIBRATION** (Assist. Scientist Flores)
- **PHOTON CALIBRATION AND IDENTIFICATION** (Postdoc Fang)  
The calibration constants produced by our group are used in this year's  $\pi^0$  and  $\eta^0$  analyses.
- **PHOTON PURITY** (Postdoc Fang)
- **TAU RECONSTRUCTION AND PERFORMANCE** (Assist. Scientist Vickey).  
In collaboration with other institutions we were the first in ATLAS to develop identification criteria for high  $p_T$  hadronic taus, as those expected in MSSM Higgs decays.
- **MONTE CARLO PRODUCTION** (Programmer Xu, Postdoc Peng and Grad. Student Li).  
We have produced tens of millions of Monte Carlo events which were added to the central production pool.

# CONTRIBUTION TO ATLAS COMPUTING SYSTEM COMMISSIONING (Physics with $\sqrt{s} = 14$ TeV)

**(CSC) BOOK (CERN-OPEN-2008-20, <http://cdsweb.cern.ch/record/1125884> )**

*In anticipation of data taking, the ATLAS Collaboration has mounted a major effort to prepare over 50 CSC notes for publication (CERN OPEN 2009-20) . Members of our group either led or were heavily engaged in 25 CSC notes in which our names are listed as co-authors ( in the form of “prepared by” ).*

- Detector performance**
1. Calibration and Performance of the Electromagnetic Calorimeter
  2. Reconstruction and Identification of Electrons
  3. Reconstruction and Identification of Photons
  4. Reconstruction of Photon Conversions
  5. Reconstruction of Low-Mass Electron Pairs
  6. Muons in the Calorimeters: Energy Loss Corrections and Muon Tagging
  7. Reconstruction and Identification of Hadronic Tau Decays
  8. Jet Energy Scale: In-situ Calibration Strategies
  9. Measurement of Missing Transverse Energy in ATLAS
- SM** → 10. A Study of Minimum Bias Events

- Higgs**
- 11. Prospects for the Discovery of the Standard Model Higgs Boson Using the  $H \rightarrow \gamma\gamma$  Decay
  - 12. Search for the Standard Model  $H \rightarrow ZZ^* \rightarrow 4\text{leptons}$
  - 13. Search for the Higgs boson via Vector Boson Fusion production process in the di-tau channels
  - 14. Higgs Boson Searches in Gluon Fusion and Vector Boson Fusion using the  $H \rightarrow WW$  Decay Mode
  - 15. Discovery Potential of  $h/A/H \rightarrow \tau^+\tau^- \rightarrow \ell^+\ell^- 4\nu$
  - 16. Charged Higgs Boson Searches
  - 17. Statistical Combination of Several Important Standard Model Higgs Boson Search Channels

- SUSY**
- 18. Data-Driven Determinations of W, Z and Top Backgrounds to Supersymmetry
  - 19. Estimation of QCD Backgrounds to Searches for Supersymmetry
  - 20. Prospects for Supersymmetry Discovery Based on Inclusive Searches
  - 21. Multi-Lepton Supersymmetry Searches

- W', Z'**
- 22. Dilepton resonances at high mass
  - 23. Lepton plus Missing Transverse Energy Signals at High Mass

- Trigger**
- 24. Trigger for Early Running
  - 25. Physics performance studies and strategy of the Electron and Photon Trigger Selection

# TALKS GIVEN IN ATLAS WORKING GROUPS

(January 2007-July 2010)

*Importance is placed in giving many talks in the ATLAS working groups.*

<b>ATLAS Working Groups</b>	<b>Number of Talks</b>	<b>ATLAS Working Groups</b>	<b>Number of Talks</b>
<b>Higgs</b>	<b>275</b>	<b>Jet Etmiss, Egamma, Tau, TileCal, b-tag</b>	<b>124</b>
<b>SUSY</b>	<b>105</b>	<b>US ATLAS Physics</b>	<b>12</b>
<b>Exotics</b>	<b>110</b>	<b>High Level Trigger</b>	<b>72</b>
<b>SM</b>	<b>66</b>	<b>Computing Operations</b>	<b>33</b>
<b>Statistics Forum</b>	<b>30</b>	<b>SCT, PAT, Physics Validation, Data Quality, Other</b>	<b>65</b>
<b>TOTAL TALKS IN ATLAS WORKING GROUPS (Jan.2007-July 2010)</b>			<b>892</b>

- **Talks Given at Conferences and Workshops**  
(74 talks from Jan. 2007 to April 2010)  
<http://wisconsin.cern.ch/a/ATLAS-CONF-TALKS.html>
- **Publications**  
(29 conference proceedings publications from Jan. 2007 to April 2010)  
<http://wisconsin.cern.ch/a/ATLAS-PUB.html>
- **ATLAS Physics Notes by Wisconsin**  
(41 ATLAS Notes from Jan. 2007-April 2010)  
<http://wisconsin.cern.ch/a/ATLAS-NOTES.html>

# WISCONSIN LEADERSHIP ROLES AND RESPONSIBILITY IN ATLAS

## Memberships, Convenorships and Responsibility Roles (2007-April 2010)

Name	Appointment	Period
Andre Dos Anjos	Co-leader of the event format group	2007-present
R. Asfandiyarov	In charge of the Higgs→WW validation	2009-present
German Carrillo	In charge of Higgs→ZZ→4leptons validation	2009-present
German Carrillo	Member of ATLAS Higgs cross section task force	2010
Yaquan Fang	Referee for ATLAS note ATL-COM-PHYS-2010-107 (H→γγ)	2010
Yaquan Fang	Coordinator of a conf. note on H→WW backgrounds	2010
Luis Flores	Coordinator of the first ATLAS W' publication	2010
Luis Flores	Co-convenor for Exotic subgroup on leptonic channels	2008-present
Luis Flores	Editor of the W' CSC note	2007-2008

<b>Luis Flores</b>	<b>Convener for Monte Carlo production in <math>H \rightarrow ZZ \rightarrow 4</math> leptons</b>	<b>2007-2009</b>
<b>Luis Flores</b>	<b>Referee for ATLAS note ATL-COM-PHYS-2009-449 (J/Psi)</b>	<b>2009</b>
<b>Bruce Mellado</b>	<b>Convener of the Higgs <math>\rightarrow</math> WW analysis sub-group</b>	<b>2008-2010</b>
<b>Bruce Mellado</b>	<b>Member of US ATLAS Resource Allocation Committee</b>	<b>2005-2009</b>
<b>Bruce Mellado</b>	<b>Co-convener US ATLAS Standard Model and Higgs forum</b>	<b>2006-2008</b>
<b>Bruce Mellado</b>	<b>Co-convener of Higgs <math>\rightarrow \gamma\gamma</math> CSC note</b>	<b>2006-2008</b>
<b>Bruce Mellado</b>	<b>Co-convener of W/Z+jets CSC note</b>	<b>2006-2008</b>
<b>Sanjay Padhi</b>	<b>Member of Grid Tools and Services Coordination</b>	<b>2007-2008</b>
<b>Sanjay Padhi</b>	<b>Member of ATLAS LCG-EGEE Task Force</b>	<b>2007-2008</b>
<b>Sanjay Padhi</b>	<b>Leader of CRONUS-ATLAS Production System</b>	<b>2006-2007</b>
<b>Sanjay Padhi</b>	<b>Member of ATLAS Computing Operations</b>	<b>2006-2007</b>
<b>William Quayle</b>	<b>On editorial board for a series of 5 Emiss/Jet conference notes</b>	<b>2010</b>

<b>William Quayle</b>	<b>On editorial board for the ATLAS detector performance journal publication</b>	<b>2010</b>
<b>William Quayle</b>	<b>Representative of the Higgs Group for ATLAS / CMS statistics forum</b>	<b>2007-present</b>
<b>William Quayle</b>	<b>Co-convener of the Higgs→WW CSC note</b>	<b>2006-2008</b>
<b>Tapas Sarangi</b>	<b>Coordinator of background estimation in W/Z plus jets group for the first publication on 7 TeV data</b>	<b>2010</b>
<b>Tapas Sarangi</b>	<b>Referee for ATLAS note ATL-COM-PHYS-2009-529</b>	<b>2009</b>
<b>Haichen Wang</b>	<b>In charge of the Higgs→<math>\gamma\gamma</math> validation</b>	<b>2009-present</b>
<b>W. Wiedenmann</b>	<b>Coordinator of DAQ/HLT applications working group</b>	<b>2007-present</b>
<b>W. Wiedenmann</b>	<b>Member of DAQ/High Level Trigger Coordination Group</b>	<b>2006-present</b>
<b>Sau Lan Wu</b>	<b>Member of Top Cross-section Review Committee</b>	<b>2010</b>
<b>Sau Lan Wu</b>	<b>Member of Advisory Board: Western ATLAS Tier 2</b>	<b>2006-present</b>
<b>Haimo Zobernig</b>	<b>Member of DAQ/ High Level Trigger Coordination Group</b>	<b>2006-present</b>
<b>Haimo Zobernig</b>	<b>Co-coordinator of March 2007 TDAQ “Technical Run”</b>	<b>2007</b>
<b>Haimo Zobernig</b>	<b>Head of ATLAS TDAQ Speakers Committee</b>	<b>2007-2009</b>
<b>Haimo Zobernig</b>	<b>Co-coordinator of DAQ/HLT Level-2 working group</b>	<b>2007-present</b>

# Leadership at ATLAS

## Task H-2 (Pan & Mellado)

- **Y.Pan chaired the session “Detectors and Performance (Calorimetry) at the 4<sup>th</sup> ATLAS Physics Workshop of the Americas (August 2010)**
- **Y.Pan to join the TileCal publications committee**
- **B.Mellado is the convenor of the H->WW group**
  - **Editor of the two ATLAS public notes in 2010**
- **B.Mellado to chair MissingET cleaning session at the ATLAS-wide Hadronic calibration workshop (September 2010)**
  - **TileCal contact person**
- **B.Mellado appointed ATLAS contact person for data-driven extraction methods for H->WW,ZZ searches**
- **B.Mellado was a member of the Higgs cross-sections task force**
- **B.Mellado was a member of the US ATLAS Tier3 task force**
- **B.Mellado is a member of the ATLAS cross-section task force**
- **B.Mellado is a member of US ATLAS panel “Collaboration involvement in remote analysis”**

# HIGGS PHYSICS

*From 2007 to April 2010, 255 talks in Higgs working groups.*

List and content of the talks: <http://wisconsin.cern.ch/physics/t.html>

- Our group has maintained a strong role in the preparation of the main Higgs search channels in ATLAS
  - $H \rightarrow WW$  with 0, 1 or 2 high  $p_T$  jets
  - $H \rightarrow \gamma\gamma$  with 0, 1 or 2 high  $p_T$  jets
  - $H \rightarrow 4$  leptons
  - $H \rightarrow \tau\tau$

*and their combination*
- Postdoc Quayle was **co-editor of the  $H \rightarrow WW$  section** in CERN-OPEN-2008-020 (the *CSC book*).
- Prof. Mellado is currently the **convener** of the ATLAS  $H \rightarrow WW$  subgroup, and was **co-editor** of the  $H \rightarrow \gamma\gamma$  section in the *CSC Book*
- **Twelve notes** by our group have been refereed and approved as ATLAS INT by the collaboration.

# HIGGS PHYSICS. $H \rightarrow WW$ @ 14 TeV

(Profs. S.L.Wu and Mellado, Postdocs Fang, Quayle, Grad. Students Asfandiyarov, Carrillo)

**Three ATLAS refereed INT notes, extensive contributions to the CSC  $H \rightarrow WW$  chapter, one ATLAS PUB (public note).**

- **“Higgs Boson Searches in Gluon Fusion and Vector Boson Fusion using the  $H \rightarrow WW$  Decay Mode,”**  
The ATLAS Collaboration, in ATL-PHYS-PUB-2009-056  
( <http://cdsweb.cern.ch/record/1174270> ).
- **“Multivariate and Fit-based Approaches to  $H+0j$ ,  $H \rightarrow WW \rightarrow l\nu l\nu$ ,”**  
Mellado, Quayle, Vickey, and S.L. Wu,  
ATL-PHYS-INT-2009-083 .
- **“Background Determination in the  $H+2j$ ,  $H \rightarrow l\nu qq$  Analysis,”**  
Goldschmidt, Mellado, Padhi, Quayle, and S. L. Wu,  
ATL-PHYS-INT-2009-061.
- **“Fit-based Search for  $H+2j$ ,  $H \rightarrow WW \rightarrow e\nu\mu\nu$ ,”**  
Mellado, Quayle, and S.L.Wu,  
ATL-PHYS-INT-2009-062 .

# HIGGS PHYSICS. $H \rightarrow WW$ @ 10 and 7 TeV

(Profs. S.L.Wu, Postdocs Fang, Ma, Quayle, Grad. Students Asfandiyarov and Carrillo)

## Five ATLAS INT notes, one PUB, one COM.

- **“Prospects for  $H+0j$ ,  $H \rightarrow WW \rightarrow l\nu l\nu$  in 10 TeV Collisions,”**  
Asfandiyarov, Carrillo, Fang, Ma, Quayle, S.L.Wu,  
ATL-PHYS-INT-2010-032 [includes 7 TeV results]
- **“Prospects for  $H+1j$ ,  $H \rightarrow WW \rightarrow l\nu l\nu$  in 10 TeV Collisions,”**  
Asfandiyarov, Carrillo, Fang, Ma, Quayle, S.L.Wu,  
ATL-PHYS-INT-2010-045 [includes 7 TeV results]
- **“Prospects for  $H+2j$ ,  $H \rightarrow WW \rightarrow l\nu l\nu$  in 10 TeV Collisions,”**  
Asfandiyarov, Carrillo, Fang, Ma, Quayle, S.L.Wu,  
ATL-PHYS-INT-2010-010 [includes 7 TeV results]
- **“Estimation of Backgrounds for  $H \rightarrow WW$  with Data-Driven methods,”**  
Asfandiyarov, Carrillo, Fang, Ma, Quayle, S.L.Wu,  
ATL-COM-PHYS-2009-607
- **“Combined Sensitivity to  $H \rightarrow WW \rightarrow l\nu l\nu$  in 7 TeV Collisions at ATLAS,”**  
Asfandiyarov, Carrillo, Fang, Ma, Quayle, S.L.Wu,  
ATL-PHYS-INT-2010-047.
- **“Prospects for Higgs Boson Searches using the  $H \rightarrow WW$  Decay Mode with the ATLAS Detector for 10 TeV,”** The ATLAS Collaboration, ATL-PHYS-PUB-2010-005,  
( <http://cdsweb.cern.ch/record/1270568> )

# COMBINATION OF $H \rightarrow WW$ CHANNELS

## Combining $H \rightarrow WW$ with 0, 1, 2 high- $p_T$ jets:

- $1 \text{ fb}^{-1}$ , 7 TeV :  $m_H$  expected exclusion from **137 to 185 GeV**  
Tevatron exclusion (all channels): 158 to 175 GeV

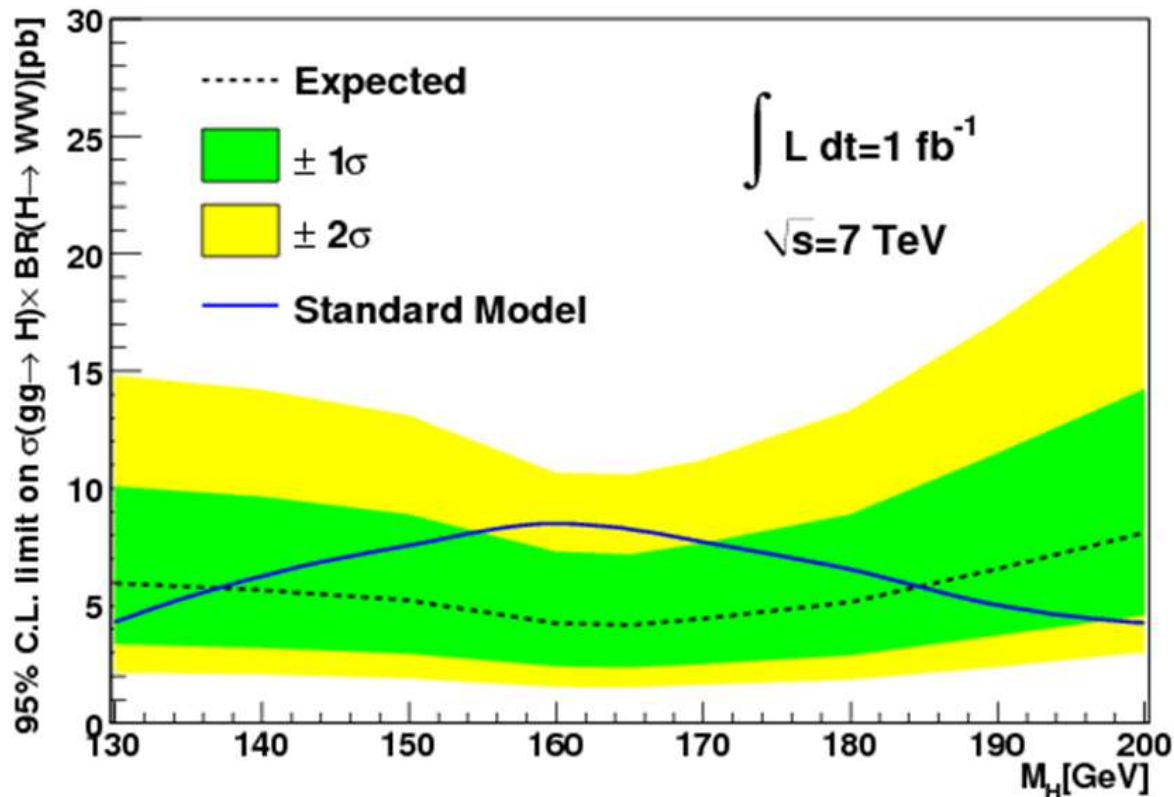

Prepared by  
Postdoc Quayle

# HIGGS PHYSICS. $H \rightarrow \gamma\gamma$ with 0, 1, 2 jets

(Profs. S.L.Wu, Pan and Mellado, Postdoc Fang, Grad. student Wang )

Prof. Mellado was co-editor of the  $H \rightarrow \gamma\gamma$  section in CERN-OPEN-2008-020  
( <http://cdsweb.cern.ch/record/1125884> )

- One of the most promising channels for  $m_H < 140 \text{ GeV}$ .
- Our group demonstrated a significant increase in sensitivity by using information about associated jets.

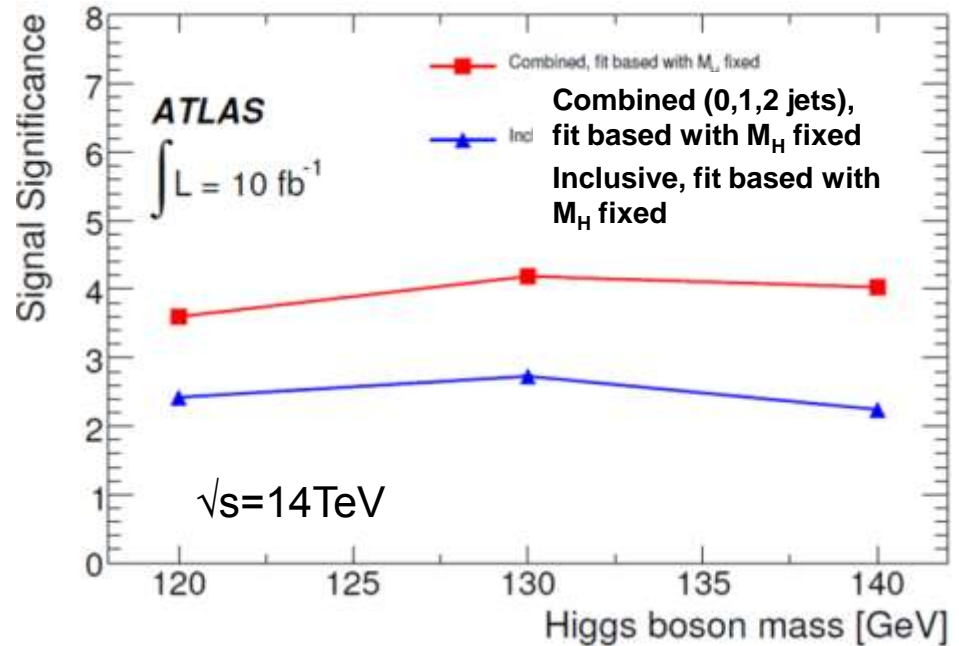

- “**Search of the Standard Model Higgs boson with  $H \rightarrow \gamma\gamma$ ,**”  
Fang, Mellado, Pan, and S.L.Wu, ATL-PHYS-INT-2009-081
- “**Prospects for the exclusion of a SM Higgs decaying to two photons,**”  
Fang, Mellado, S.L.Wu and other ATLAS collaborators, ATL-PHYS-INT-2010-061

# HIGGS PHYSICS. $H \rightarrow ZZ \rightarrow 4l$

(Prof. S.L.Wu, Assist. Scientist Flores, Postdoc Quayle, Grad. student Carrillo)

## The “golden channel”

- We have studied its statistical properties and its combination with other channels,
- We developed a fit-based analysis that accounts properly for the “look-elsewhere” effect.

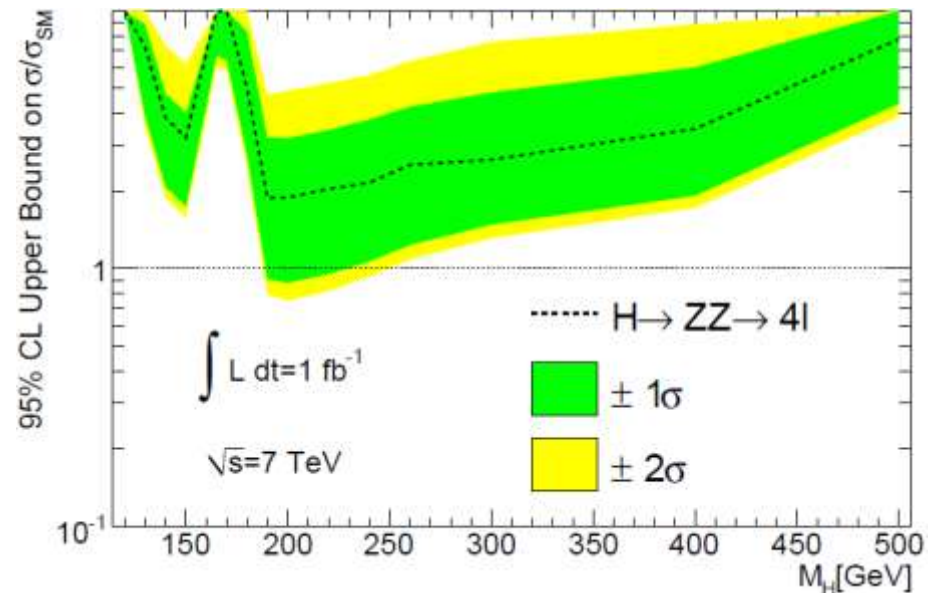

- “Search for  $H \rightarrow ZZ \rightarrow 4l$  using a global fit procedure,”  
[Flores, Quayle, and S.L. Wu](#), ATL-PHYS-INT-2009-043
- “ATLAS sensitivity prospects for the SM Higgs boson in the decay channel  $H \rightarrow ZZ^{(*)} \rightarrow 4l$  at  $\sqrt{s}=10$  and 7 TeV,” [Anastopoulos et al.](#), ATL-PHYS-INT-2010-062
- “Using the Profile Likelihood to Set Limits on  $H \rightarrow ZZ \rightarrow 4l$ ,”  
[Quayle, Wu](#), ATL-COM-PHYS-2010-459

# HIGGS PHYSICS. $H \rightarrow \tau\tau$ , $H \rightarrow \mu\mu$

(Profs. S.L.Wu and Mellado, Assist. Scientist Vickey, Postdoc Quayle, Grad. Student Chen)

Our group developed data-driven methods to estimate backgrounds to  $H \rightarrow \tau\tau$  and a fit-based analysis of this channel.

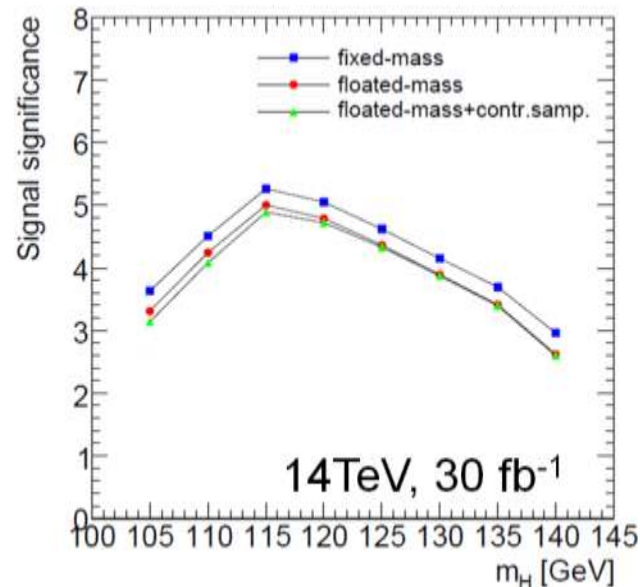

- “Searching for New Physics Using High-Pt Tau Pair in ATLAS,”  
Mellado, Vickey, S.L.Wu, ATL-PHYS-INT-2008-038
- “A Data-driven Control Sample for  $Z \rightarrow \tau\tau$ +jets Backgrounds to Higgs Searches,”  
Vickey, Chen, Mellado, Quayle, and S.L.Wu, ATL-COM-PHYS-2008-144
- “Search of a SM Higgs in the VBF  $H \rightarrow \tau\tau$  channel at ATLAS,”  
Chen, Mellado, Vickey, and S.L.Wu, ATL-PHYS-INT-2009-030
- “b-Tag-Independent Search for the Neutral MSSM Higgs Boson in the Dimuon Decay Channel,” Mellado, S.L.Wu and other ATLAS collaborators, ATL-PHYS-INT-2009-086

# COMBINED HIGGS SENSITIVITY

Our group has played a leading role in the ATLAS Higgs combination results for several years.

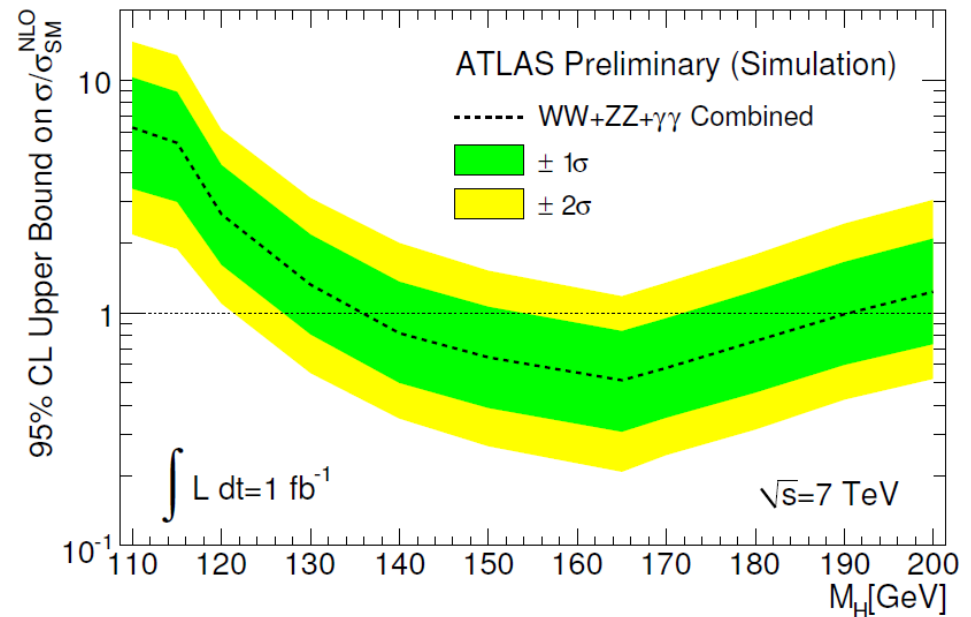

- "Higgs Boson Production Cross Sections and Decay Branching Ratios," Carrillo, Mellado and Viquey and other ATLAS collaborators, ATL-PHYS-INT-2010-030
- "ATLAS Sensitivity Prospects for Higgs Boson Production at the LHC Running at 7 TeV," The ATLAS Collaboration [ATL-PHYS-PUB-2010-009]
- "Expected Combined Sensitivity to the Standard Model Higgs boson at a 7 TeV Centre-of-Mass Energy Using Monte Carlo Simulation," (contribution to the draft above; WW/ZZ/ $\gamma\gamma$  combination) [ATL-PHYS-INT-2010-064]

# SUPERSYMMETRY

(Profs. S.L.Wu and Pan, Postdocs Chen, Poveda, Sarangi, and Grad. Student A. Castaneda)

***From 2007 to April 2010, 85 talks in SUSY working groups.***

List and content of the talks: <http://wisconsin.cern.ch/physics/t.html>

We have contributed extensively in several areas of SUSY studies in ATLAS:

- ***Inclusive SUSY studies***
  - One lepton + etmiss
  - Two leptons + etmiss
  - Three leptons + etmiss
- ***Fit-based analysis for one-lepton + etmiss channel***

# SUPERSYMMETRY

## SUSY PARAMETER SCANS

The minimal SuperGRAvity (mSUGRA) model reduces the number of free parameters to only five. We have studied the analysis potential at 10 and 7TeV. For low sparticle masses, discovery could be possible within  $100 \text{ pb}^{-1}$  at 7 TeV.

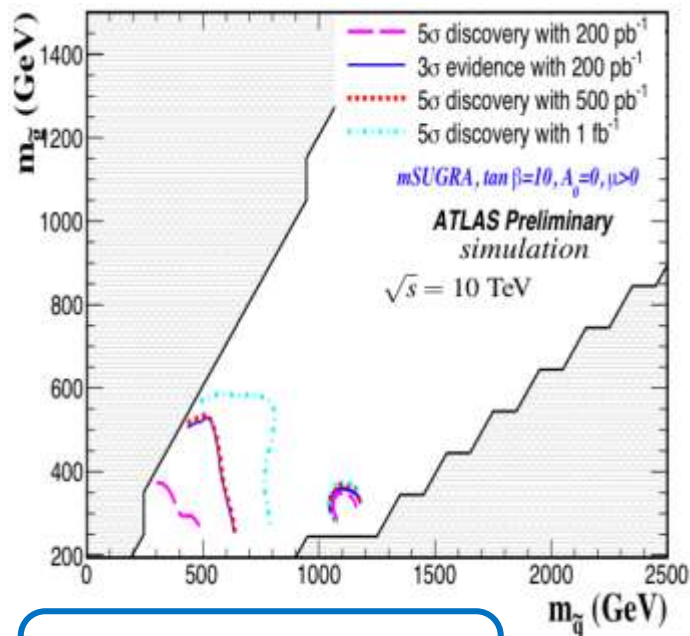

Two lepton + Emiss

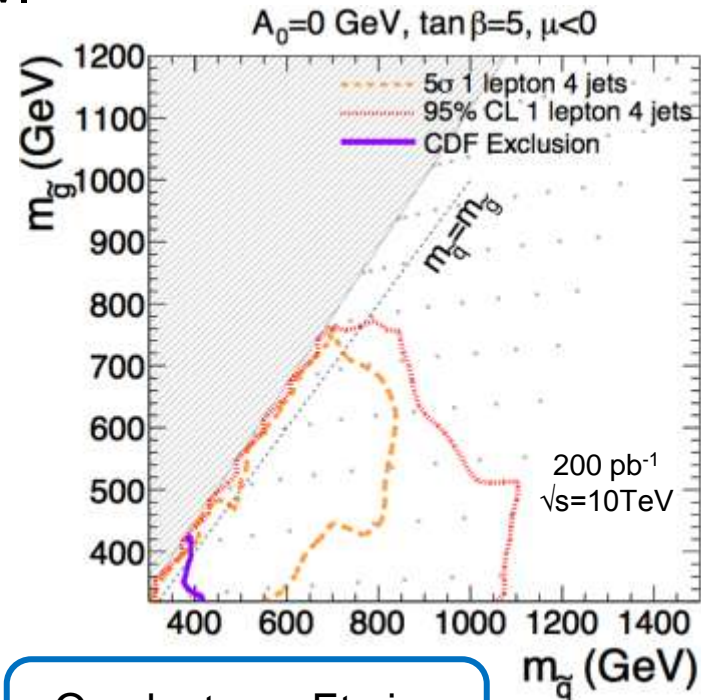

One lepton + Emiss

# SUPERSYMMETRY

## Two PUB notes, three INT note, one COM

- **“Data-driven determinations of W, Z and top background to Supersymmetry searches at the LHC,”**  
B. Mellado, T. Sarangi, S. L. Wu and other ATLAS collaborators  
ATL-PHYS-INT-2008-030
- **“SUSY searches in the lepton plus inclusive jets plus missing transverse energy final state,”**  
Pan, Fang, Sarangi and S. L. Wu  
ATL-PHYS-INT-2009-031
- **“Searching for Supersymmetry with two same-sign leptons, multi-jets plus missing transverse energy in ATLAS at  $\sqrt{s}=10$  TeV,”**  
Sarangi, Chen, A. Castaneda, Pan, Poveda and S.L. Wu,  
ATL-PHYS-INT-2009-065.  
Approved by ATLAS to be publicly available as ATLAS-PHYS-PUB-2009-085.
- **“Initial sensitivity of ATLAS inclusive SUSY search at  $\sqrt{s}=10$  TeV in the one-lepton final state by fitting and number counting,”**  
Chen, A. Castaneda, Pan, Poveda, Sarangi and S.L. Wu,  
ATL-COM-PHYS-2010-050.

# SUPERSYMMETRY

- **“Discovery Potential and Exclusion Limits for R-Parity Conserving SUSY Signals at  $\sqrt{s} = 10$  TeV in ATLAS,”**  
Poveda, A. Castaneda, Chen, Pan, Sarangi and S.L. Wu,  
ATL-PHYS-INT-2009-114.
- **“Prospects for Supersymmetry discovery based on inclusive searches at a 7 TeV centre-of-mass energy with the ATLAS detector,”**  
A. Castaneda, Chen, Poveda, Sarangi, S.L. Wu *et al.*,  
ATL-PHYS-INT-2010-051.  
Approved by ATLAS to be publicly available as ATL-PHYS-PUB-2010-010.

# EXOTIC PHYSICS

*From 2007 to April 2010, 96 talks in Exotic working groups.*

List and content of the talks: <http://wisconsin.cern.ch/physics/t.html>

Luis Flores is co-convener of the ATLAS Lepton+X Exotics subgroup, which is in charge of physics searches involving leptons or photons.

- Our group has been strongly involved in several exotic physics searches
- We provided physics prospects to the Chamonix workshops in 2009 and 2010 for discussions on the initial LHC energy.
- **ONE LEPTON + MISSING ENERGY ( $W' \rightarrow l\nu$ )**  
(Prof. S.L.Wu, Assist. Scientist Flores, Grad. Student Pedraza)
- **DILEPTON SEARCH ( $Z' \rightarrow ll$ )**  
(Prof. S.L.Wu, Assist. Scientist Flores, Grad. Student Castaneda)
- **TOPOLOGICAL SEARCH**  
(Profs. S.L.Wu and Pan, Postdocs Peng and Sarangi, Grad. Student Wang)  
We have implemented a model-independent search that relies only on the event topology (for example,  $e^+e^+$ ,  $e^-e^-$ ,  $\mu^+\mu^+\mu^+$ ).

# EXOTIC PHYSICS

## One PUB note, two INT notes, two COM

- **“Z’ to ll prospects as a function of LHC center-of-mass energy with ATLAS,”** [E. Castaneda, Flores, S.L.Wu](#), ATL-PHYS-INT-2009-036.
- **“W’ to lepton-neutrino prospects as a function of LHC center-of-mass energy with ATLAS”**, [Flores, Pedraza, S.L.Wu](#), ATL-PHYS-INT-2009-038.
- **“Potential discovery of a W’ signal with the ATLAS Detector at  $\sqrt{s}=10$  TeV and  $\sqrt{s}=7$  TeV”**, [Flores, Pedraza, S.L.Wu](#), ATL-COM-PHYS-2010-354.
- **“ATLAS sensitivity prospects to W’ and Z’ in the decay channels  $W’\rightarrow l\nu$  and  $Z’\rightarrow l+l-$  at  $\sqrt{s}=7\text{TeV}$ ”**, [The ATLAS collaboration](#). ATL-PHYS-PUB-2010-007.
- **“Searching for Hints of New Physics using a Topological Method in ATLAS at  $\sqrt{s}=10\text{TeV}$ ”**, [Pan, Peng, Flores, Sarangi, Wang, S.L.Wu](#). ATL-COM-PHYS-2009-600

# STANDARD MODEL PHYSICS

*From January 2010 to April 2010, 25 talks in Standard Model working groups.*

List and content: <http://wisconsin.cern.ch/physics/t.html>

## CONTRIBUTIONS TO STANDARD MODEL JET SUBGROUP

(Prof. S.L.Wu, Postdoc Poveda and Grad. Student Li)

- “Inclusive Jet Transverse Momentum Unfolding in ATLAS”,  
Poveda, Li and S.L. Wu. ATL-PHYS-INT-2010-063

## W/Z PRODUCTION CROSS-SECTIONS

(Profs. S.L.Wu, Pan and Mellado, Postdoc Zhu, Grad. Student Carrillo)

- ATLAS Standard Model Cross Section recommendations for 7 TeV LHC running (to appear), Mellado and other ATLAS collaborators,

## Z+JETS CROSS SECTION

(Profs. S.L.Wu, Pan and Mellado, Postdoc Sarangi)

- “Prospects for W/Z+jets early data measurements with the ATLAS detector at the LHC,”  
Fang, Pan, Sarangi, S.L.Wu and other ATLAS collaborators, ATL-COM-PHYS-2010-150

## NORMALIZATION OF WEAK BOSON PAIR PRODUCTION

(Profs. S.L. Wu and Mellado, Postdoc Fang, Grad. Student E. Castaneda and two collaborators from other institutions)

- "Normalizing Weak Boson Pair Production at the Large Hadron Collider,"  
E. Castaneda-Miranda; Fang; Mellado; Wu, Sau Lan et al.  
Phys. Rev. D80:054023,2009 ( <http://prd.aps.org/abstract/PRD/v80/i5/e054023> )

# Summary (Task H-1, WU)

- 1. After 16 years preparation, for the first time I can show you results from collision data. Our hard work begins to bear fruit.***
- 2. From April to August, 2010, We (TASK H-1 Wu) are contributing significantly to 25 results for summer conferences (5 detector performance results from data and 15 physics results from data)***
- 3. University contribution equivalent to a one-to-one matching to the DOE grant.***
- 4. Strive for new physics and discovery at LHC***